

AIRFORCE HOVER MOWER

Owner's Manual

F-15

Issue: NHS 06-2018
Start: S/N AF15-11862



Other Equipment from Seago

Air Force Hover Mowers: Air Force Hover Mowers come in two models, the full size F-19 and the smaller, 2-stroke F-15.

Atom Edgers: The Atom Cart Path Edger is fastest walk-behind edger in the world. Shaft drive and cross over blades for unmatched speed and safety. The optional Wire Wheel Brush Blade is outstanding on asphalt paths.

BowDry: Quiet and incredibly efficient, the BowDry REMOVES water, it doesn't just move it. The large foam wrapped roller collects standing water off any surface and then it is syphoned off into a 16 gallon rear holding tank.

Hover Trimmer: This dynamic attachment will turn any string trimmer into a hovering trimmer for grass or brush. The shaped Quad-blade provides anti-scalping float while the hood keep debris away from the operator.

Masport Mowers: Three models all featuring the commercial grade Briggs & Stratton 850 Series engine and single handle height of cut adjustment.

Rotarola is a rear roller rotary mower that delivers an excellent cut and dynamic stripe at a reasonable cost. The Rotarola provides look of a reel cut with the low maintenance and convenience of a rotary.

M800ST SP is a 3-N-1 (rear bag, side discharge and mulch) 21" wide steel deck mower with commercial grade, axle mounted gear box, sturdy collection bag and adjustable handle.

M800 Utility is a bullet proof side discharge push mower. Extra heavy duty deck, firm external frame and bearings on all wheels make a rugged yet easy to use mower.

PortaPump and PortaPump Junior: An incredibly portable 33 GPM trash pump powered by a 35cc Honda commercial engine. A one person pump station that is perfect for draining bunkers, flooded areas, plugged drains and irrigation breaks. The **PortaPump Junior** is a commercial grade 30 GPM trash pump that mounts to your string trimmer or brush cutter instantly converting it to a pump station.

Spyker Spreaders: Spyker offers various sized of walk-behind, tow-behind, electric, drop and ride on spreaders. Spyker is competitively priced and offers a lifetime warranty on its metal gears and superior components and workmanship. Compare Spyker to other brands and see the difference in the quality of the machine and the performance on your turf.

For more information or to locate the dealer nearest you, please call 800-

©2016 Air Force Hover Mowers, Inc.
Printed in the United States of America

Table of Contents

Contents	3	Engine Care	16
		Running the Engine	16
Specifications	4	Stopping the Engine	16
Introduction	5	Machine Maintenance	17-19
Description of Intended Use	5	Cleaning the Air Cleaner	17
Foreseeable Misuse	5	Servicing the Spark Plug	17
Warranty	6	Keeping the Engine Clean	17
		Deck Housing	17
Safety Symbols	7	Nuts and Bolts	18
		Fuel Maintenance	18
Safety Precautions	8	Maintaining the cutting System	18
Residual Risk	8	Sharpening the SS Blades	19
Preparation	8-10	Mower Storage	19
Transport	11		
Maintenance & Storage	11	Maintenance Schedule	20
		Service Scheduling	20
Machine Assembly	12	Troubleshooting	21
Before Starting the Machine	13	Diagrams	22-25
Prevent Engine Damage	13	Mower Diagram	22
Fuel Mixing Instructions	13	Mower Parts List	23
Fuel Level Check	13	Engine Diagram	24
Fuel Type	13	Engine Parts List	25
Air Filter Check	13		
Operating the Machine	14-15	Notes	26-27
Starting the Machine	14		
Cutting Flat Landscapes	14	Customer Information	28
Cutting Slopes and Banks	14		
Stopping the Machine	15		
Cutting Height Adjustment	15		

Specifications

Mower Model: F-15
Engine: JN-60
Engine Type: 2-stroke
Engine Size: 63.3cc
Engine Speed: 5,500 RPM
Fuel Type: 25:1
Fuel Capacity: 0.3 gallons
Engine Oil Type: 2-stroke oil
Cutting Width: 15 inches
Dry Weight: 22 pounds
Vibration Level: 21 m/s²
Recorded Noise Level: 90 db(A)



Introduction

Thank you for purchasing the Air Force Hover Mower. The following pages are to give you information about maintenance, operation, safety and specifications instructions regarding your new mower. We strongly recommend reading the manual before your first use.

All references to the left and right side of the machine are as viewed from behind the mower in the operator's position.

This manual is written based on information available at the time of publications. Air Force reserves the right to amend the product, specifications, and information within the manual without prior notification.

Description of Intended Use

The Air Force Hover Mower is designed for cutting grass and low-to-the-ground vegetation. It consists of one JN-60 2-stroke engine, robust one-piece injection molded cutting area and support frame; pivoting two-piece fixing bracket and operators guide handle; pivot handle release foot lever; throttle control cable, and engine break cable.

The Air Force Hover Mower should only be operated, repaired or serviced by persons knowledgeable about the machine and familiar with the safety features. Correct operation and maintenance will ensure the long service of the machine.

The machine should only be used by trained personnel and outside in clear weather conditions.

Foreseeable Misuse

Any other use, other than the cutting of grass and low-lying vegetation, is considered contrary to the intended use of the machine. Strict adherence and compliance with the conditions of operation, repair, and service as stated in this manual are required.

Do not operate the machine if you have not been trained. Do not climb, sit or step on the deck, engine or handles of the machine. Do not start the machine unless it is on flat ground in a safe area away from any debris that can fly

Warranty

LIMITED WARRANTY

The manufacturer warrants to the original purchaser that this unit shall be free from defect in material and workmanship under normal use and service for a period of **one year** from the date of purchase. The manufacturer of the engine furnishes their own warranty and services through their authorized network. The manufacturer is **not** included in said network.

To qualify for the full benefit of the Air Force warranty, the warranty registration card must be returned to the distributor. If your selling dealer does not offer this service, please fill out and return the enclosed warranty registration card. Subject to the conditions and exclusions noted in the Limited Warranty, we shall at our option, repair or replace any warranty part during the applicable period. If you are in doubt or experience any difficulty, please consult your Authorized Dealer for clarification.

A 90-day warranty period applies to those items which are subject to normal wear and tear: blade systems, cables, etc.

This warranty does not apply to any unit that has been tampered with, altered, misused, abused or used for hire, and will become invalid if non-genuine parts are fitted at any time. This warranty does not cover minor mechanical adjustments unless they are due to defective material or workmanship. Consult the Owner's Manual or your Authorized Dealer for assistance when making these adjustments.

To make a warranty claim, contact your Authorized Dealer with your proof of purchase, which states the machine serial number and date of purchase. The dealer will, at our option, repair or replace any warranty part within the duration of the warranty period. If your dealer does not provide services, please contact the distributor directly with your proof of purchase.

This limited warranty gives you specific legal rights and is in addition to any statutory rights to which you may be entitled; your statutory rights are not affected by this warranty.

US / CANADA ONLY: Information regarding Authorized Dealers can be obtained by contacting Seago International.

Web: www.seagousa.com

Phone: (800) 780-9889

Safety Symbols

Manual: Read the instruction manual before using machine.

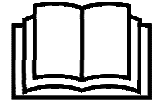

Use the Manual: Refer to the manual when making any adjustments or repairs to the machine.



Spark Plug: Disconnect the spark plug when doing any work on the machine .



Hot Surface: Be aware of the hot surfaces of your machine during and after use.



Protective Gear: Always wear protective ear and eye gear when operating the machine.



Safe Distancing: Keep a safe distance of pedestrians and pets while the machine is in operation due to flying debris.

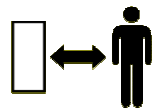

Safe Footing: Be aware of your footing and wear the proper footwear when operating the machine on an incline.



Warning: Always be alert of possible hazards and your work environment.



Safety Precautions

Your machine is perfectly safe if used correctly. Failure to observe the following precautions may result in serious injury.

Residual Risks

Exhaust contains poisonous carbon monoxide. Do not run the engine without adequate ventilation, and never run the engine indoors.

The engine and exhaust become hot during use. Keep the engine 1 meter (3 feet) away from buildings and other equipment during operation. Use heat resistant gloves when working with the engine block during or after use.

The engine uses flammable liquids. Keep fire elements away from the machine and store flammable liquids safely.

Operators are to use safety gear at all times. The blade system can cause injury if it comes in contact with the body, can expel sand, dirt, rocks, sticks, etc. during use.

Training

Read the Owner's Manual and other informational material that came with your new mower. If the operator or mechanic cannot read English, it is the owner's responsibility to explain this material to them.

Become familiar with the safe operation of the mower, operator controls, and safety signs.

All operators and mechanics should be trained. The owner is responsible for training all users.

The owner/operator is responsible for and can prevent accidents or injuries occurring to themselves, others and property by adhering to the safety instructions in this manual.

Never let children or untrained people operate or service the mower. Local regulations may restrict the age of the operator.

Preparation

While using the machine, always wear substantial protective footwear and long pants. Do not operate the equipment when barefoot or wearing open-toe shoes.

Wear appropriate clothing including hard hat, safety glasses and hearing protection. Long hair, loose clothing or jewelry may get tangled in moving

Safety Precautions

Evaluate the terrain to determine what accessories and attachments are needed to properly and safely perform the job. Only use accessories and attachments approved by Air Force.

Inspect the area where the equipment is to be used and remove all objects such as rocks, toys, and wire which can be thrown by the machine.

Use extra care when handling gasoline and other flammable fuels. Vapors are explosive.

- (a) Use only approved fuel containers
- (b) Never remove fuel cap or add fuel when the engine is operating
- (c) DO NOT SMOKE while operating the machine
- (d) Never refuel or drain the machine indoors
- (e) Always use fresh fuel. Stale fuel can block the carburetor and cause leaks.

Check that the Operator Presence Control (OPC) and safety switches are attached and functioning properly.

Keep all parts in good working condition and all hardware tightened. Replace all worn or damaged decals.

Do not use near children or pets.

A damaged cutting device and/or impeller must be replaced. Before use, always visually inspect the cutting system to ensure that it is in good condition. Do not operate with an out-of-balance cutting system or impeller.

Operation

Do not operate the engine in an enclosed space where exhaust fumes (carbon monoxide) can collect. Refuel outdoors only and do not smoke while refueling.

Do not operate the machine under the influence of alcohol or drugs.

Always pull the starter cord slowly until resistance is felt. Then pull the cord rapidly to avoid kickback and prevent hand or arm injury. Ensure that feet are away from the cutting system.

Operate only in daylight or good artificial light, keeping away from holes and hidden hazards.

Safety Precautions

Avoid operating the machine in wet grass. Be sure of your footing while using this product, especially when backing up. Reduced footing could cause slipping.

Walk, never run when operating the Air Force Hover Mower.

Operate across the face of slopes, never up and down. Slow down and use extra care when making turns or changing direction on slopes. Be sure to travel in the recommended direction on slopes. Turf conditions can affect the machine's stability. Use caution while operating near drop-offs.

Never raise the deck with the blades in motion. Stop the engine before moving the machine across areas other than grass.

Never operate without the safety guards in place.

Do not change the engine governor settings or over speed the engine.

Never touch the exhaust/exhaust guard or cooling fins with the engine is hot.

Stop engine and disconnect the park plug lead:

- (1) Before clearing blockages
- (2) Before cleaning, checking or working on the machine
- (3) After striking a foreign object. Inspect the machine for damage and ensure necessary repairs are made before re-starting
- (4) If the machine starts to vibrate abnormally (check immediately).
An out of balance cutting device causes severe vibration.

Stop engine:

- (1) Whenever you leave the machine
- (2) Before refueling

Keep hands and feet away from the cutting system.

To start, machine should be on flat ground, clear of debris.

Do not start on tables, carts, vehicles, utility work spaces, etc.

Always use protective eye wear to protect from flying debris.

Always wear protective ear coverings to protect from excessive noise levels. Noise levels recorded at the Operator's position for this machine were 90 db (A).

Safety Precautions

Transport

To transport by hand, ensure footstop is securely in place, lift machine by the upper bar of the lower handle and walk the machine. If transporting over lawn, user may engage the engine and push the machine to the destination. If transporting in a utility vehicle, ensure the engine is off and do not start the engine until it is back on the lawn.

Maintenance & Storage

Disengage the drive, stop the engine and disconnect the spark plug. Wait for all movement to stop before adjusting, cleaning or repairing. Keep hands and feet away from moving parts.

Clean the cutting system, drive, muffler and engine of any grass or debris to prevent fires. Clean up any fuel/oil spills.

Never store machine with gasoline in the tank within an enclosed area where fumes may reach an open flame or spark.

Park the machine on level ground. Never allow untrained persons to service the machine.

Remove the spark plug before attempting any repairs. Never check for a spark when the spark plug is removed. Use an approved tester.

Keep all parts in good working condition and all hardware tightened. Replace all worn or damaged decals. Always replace worn or faulty parts with genuine Air Force Hover Mower parts.

Allow the engine to cool before storing in any enclosures. To reduce the risk of fire hazard, keep the engine and the surrounding deck area free of grass, leaves, and excessive grease.

Shut off fuel while storing or transporting. Do not store fuel near flames or drain indoors.

If the fuel tank has to be drained, this should be done outdoors and when the engine is cool.

Wear strong work gloves when removing and reassembling the cutting device.

Never replace the cutting mechanisms with metal parts and only use cutting mechanisms which are suitable for use at the operating speed of the machine.

Machine Assembly

Arrival Checklist

Remove the machine from its packaging and make sure you've received all of the following parts to ensure your mower is correctly assembled:

- (5) Throttle Securing Bolt
- (6) Brake Securing Bolt
- (8) Handle Securing Kit
- (10) Footstop Securing Kit
- (11) Deck/Handle Kit
- (**) Cable Ties (not shown)

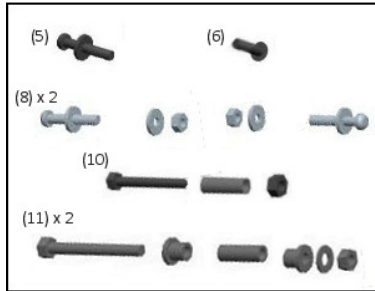

[If any pieces are missing, contact your dealer.]

Assembling the Machine

Step One: Lower Handlebar Assembly

To fit the lower handle to both sides, align the holes (footstop assembly on the right side) and insert the sleeves, bushes, bolts, washers and nuts as shown. (Uses Kit # 11 – Deck Handle Kit)

Step Two: Upper Handle Assembly

To fit the upper handle on both sides, align the holes and fit the bolts, washers, and nuts. (Uses Kit #8 – Handle Securing Kit)

Step Three: Throttle & OPC Cable Assembly

Attach the throttle assembly to the outside right handle bar using the #5 Throttle Securing Bolt & washer. (Secure the cable to the upper and lower handle using the provided ties.) Attach the OPC Cable in the front of the right handle using the #6 Brake Securing Bolt through the back of the handle.

Step Four: Footstop Assembly

To fit the footstop to the lower handle, align holes to the outside right lower handle and fit the sleeve, bolt and nut from the inside to the outside of the handle, and fit the nut to the outside of the handle. (Uses Kit #10 – Footstop Securing Kit).

Before Starting the Machine

Prevent Engine Damage

To prevent damage to the engine, the machine is shipped without any fluids. The engine must be filled with the correct grade of oil and fuel mix before starting the engine.

Fuel Mixing Instructions

When operating the Air Force Hover Mower, **always use a ration of 25:1** to ensure the highest quality performance. To prolong the life of your engine, change the oil mix after the first five hours of use.

Fuel Level Check

When filling the fuel tank, the fuel mix should fill the tank up to the base of the neck to allow for fuel expansion. Do not overfill the fuel tank.

Fuel Type

Always use clean, unleaded fuel and 2-stroke oil to mix. Purchase these liquids in a 30-day quantity to keep fresh fuel on hand.

Air Filter Check

To ensure proper air flow and maximum engine performance, check and clean the air filter often. Use gasoline to clean the filter. Once debris is cleared, dip the filter in oil and wring out. Place filter back in the case and close the air filter cover.

Starting the Machine

Ensure that the Brake Handle moves freely and returns to its resting position when released.

Starting the Machine

Step One:

Push the mower throttle control lever into the open position. Pump the primer bulb behind the fuel tank to release fuel. Close the engine choke lever. If the engine is warm, the choke may not be needed.

Step Two:

Release the handlebar from the footstop. Hold the Brake Handle to the upper handle, place your foot on the right side or on the rear of the deck. Pull the recoil starter rope lightly until you feel resistance, then pull with a slow and steady motion. Return the starter grip gently.

Note: DO NOT YANK or pull sharply on the starter as it will greatly reduce the life of the starter line and starter mechanism. It is much better to use a steady pull just hard enough to overcome the resistance of the engine compression.

Note: When pulling on the starter, try to keep a low angle so that the rope comes out of the starter case at an even and level angle. This is greatly reduce wear and tear on the starter and increase the longevity of this part.

Note: The Brake Handle must be held firmly against the handlebar to start and keep the engine running. If it is released, the engine and blade system will stop.

Step Three:

Once started, move the throttle lever to the closed position and allow the engine to warm up.

To prevent damage, never pull the recoil starter handle while the engine is running.

Operating the Machine

Cutting Flat Landscapes

Begin at the edge of the lawn and mow in a straight line back and forth as you would with a regular walk behind machine.

Cutting Slopes and Banks

Begin at the top and swing the machine from side to side while carefully and slowly moving down the slope. Keep the machine moving to reduce strain on the engine.

***Caution:** Never stand below or beside the machine while mowing an embankment. Always stand higher on the slope than the machine.*

Stopping the Machine

Release the Engine Brake Handle to stop the machine. If the engine fails to stop, pull the black rubber cover on the front of the engine to release the spark plug lead from the engine.

Cutting Height Adjustment

Your machine is shipped with the cutting disc in the highest position. Follow these steps to adjust to the desired height of cut:

- (1) Disconnect the spark plug.
- (2) Tilt the machine onto its left side, keeping the carburetor up.
- (3) Wearing protective hand gear, remove the Disc Securing Bolt with holding the cutting system.
- (4) Remove the three spacers and the cutting system.
- (5) Reposition the spacers and cutting system for desired height of cut.
- (6) Fit the Disc Securing Bolt back to the machine. Bolt should be installed to 18ft pounds of torque.

***Note:** Large spacer must be positioned directly below the impeller at all times.*

Operating the Machine

Prevent An Accident

Inspect the cutting area before using the mower. Any objects other than grass and leaves should be removed to prevent them from becoming projectiles.

Inspect for hidden obstructions, which would cause health and safety risks when coming in contact with the cutting system. Make note of the obstructions and mow around them.

Engine Care

Running the Engine

When first starting the engine, allow the engine to run 1-2 minutes at a low speed to warm it up. Once the engine is ready, adjust the throttle as needed and begin mowing.

Do not accelerate abruptly. Avoid idling the machine at a fast speed. This not only shortens the engine life but can cause internal damage of the machine and void the warranty.

Stopping the Engine

Reduce the engine speed to the lowest setting and idle for 1-2 minutes. Release the Engine Brake Handle to shut the engine down.

If the engine shows signs of distress during use, refer to the Troubleshooting section for help.

Machine Maintenance

To prevent accidents, disconnect the spark plug whenever you are performing any maintenance procedures on the machine.

Cleaning the Air Cleaner

Remove the air cleaner cover (1) by releasing the catch behind the fuel tank (2) and tilting away from the engine body until it's released. Remove the air cleaner (3) and bath the foam in fuel and oil or soap and water. If it's too dirty or damaged, replace. To clean the filter base, tap on a hard surface or blow out with air.

After cleaning the air cleaner, return it back to the case and insert the cover on the left side, pushing the cover towards the engine body until the catches hold in place.

Servicing the Spark Plug

Use only an approved spark plug tester. Replace the spark plug every 100 hours or every season (whichever occurs first).

Check the spark plug gap with a feeler gauge and calibrate at 0.5 – 0.7mm.

Keeping the Engine Clean

Remove all debris and grass from the engine, including the exhaust and exhaust guard, air ways in the top cowl, and surrounding deck areas on a daily basis or after each use. Do not pressure-wash the machine during cleaning. Water can contaminate the fuel. Always clean with a brush or compressed air.

Grass and debris may clog the engine's air cooling system especially after prolonged operation or cutting tall, dry grass. The internal cooling fans and surfaces may require cleaning to prevent the engine from overheating.

Deck Housing

Remove debris and grass from both sides of the deck immediately after each use.

Machine Maintenance

Nuts and Bolts

Check all securing nuts and bolts regularly to ensure they remain tight. Replace missing or damaged items immediately.

Fuel Maintenance

Before each use, check the fuel level and ensure that a correct level is maintained. Refer to the “Before Starting the Machine” section for instructions. **The proper ratio of fuel to oil is 25:1.**

Change the fuel after the initial first five hours of use. Follow the maintenance schedule thereafter.

Maintaining the Cutting System

The condition of the cutting system and supporting mounting system should be checked regularly for signs of wear or damage. A damaged cutting system will become out of balance and cause the machine to vibrate excessively.

The cutting

system could damage the deck, impeller and other pieces under the deck and lead to damage to engine or operator.

***DO NOT** use a damaged / unbalanced cutting system. Replace the cutting system every two years or as wear and damage demand.*

Regularly ensure the Disc Securing Bolt is tightened. Do not start machine on tables, carts, utility work spaces, vehicles, etc.

Prevent An Accident

Never work on the mower unless the spark plug lead has been removed.

***ALWAYS** wear strong gloves to protect your hands. **ALWAYS** use genuine parts.*

Machine Maintenance

To replace the cutting system:

- (1) Drain the fuel by running the engine dry (engine will stop).
- (2) Remove the spark plug lead and allow the engine to cool.
- (3) Turn the machine on its left-hand side (carburetor up).

If you only need to replace the blades or the blade securing kit, you would not need to remove the cutting disc from the machine. If you need to replace the entire cutting disc or the spacers, the disc will need to be removed by first removing the Disc Securing Bolt.

Sharpening the Stainless Steel Blades

Our stainless steel blades are reversible and can be sharpened. For best results, use both sides until they need to be sharpened, and then sharpen both sides at the same time. Blades should be sharpened every 25 hours or as needed. Sharpen with a flat file.

Prevent An Accident

Remove the cutting blades from the cutting system before sharpening. Use strong gloves while handling the blades.

Mower Storage

To prevent engine damage, engines must be drained of fuel when being stored in excess of 30 days. Removing the fuel prevents gum from forming in the fuel system and essential carburetor parts. By following our storage procedure and referring to the engine manual as needed, your machine will remain in good working order.

- (1) Drain the fuel by running the engine dry (engine will stop).
- (2) Disconnect the spark plug lead.
- (3) Remove the engine spark plug, pour 5ml of engine oil into the Spark plug hole.
- (4) Slowly pull the recoil starter rope, turning the crankcase, to distribute oil and prevent engine corrosion.
- (5) Clean all debris and grass from the engine cylinder, cooling fans, under top cowl, and around and behind the exhaust / exhaust guard.
- (6) Lubricate the machine.
- (7) Treat metal parts with a water-repellant, anti-corrosion product.
- (8) Cover the machine with a protective sheet and store it in a dry, ventilated area.

Maintenance Schedule

Service Schedule	Maintenance
Before Each Use	<ul style="list-style-type: none"> (1) Check the fuel level and look for leaks (2) Check blade system and tighten any loose bolts (3) Check air filter – ensure it is dry (4) Remove debris from the cutting system, impeller, and air intake area of engine
After the First 5 Hours	(1) Change the engine fuel (first fuel change)
Every 5 Hours	(1) Tighten/replace any loose/damaged bolts, blades or cutting disc
Every 25 Hours	(1) Check and clean the air and fuel filters.
Every 50 Hours	<ul style="list-style-type: none"> (1) Clean combustion chamber, cylinder, and muffler exhausts. (2) Clean/replace air and fuel filters (3) Sharpen/replace blades (4) Clean spark plug and recalibrate (5) Check for any leaks or deteriorations in the fuel system and hoses
Every 100 Hours	<ul style="list-style-type: none"> (1) Inspect the spark plug (2) Clean/replace air cleaner (3) Clean the cooling system (fins/starter area)
Every 150 Hours	<ul style="list-style-type: none"> (1) Replace air filter (2) Replace spark plug
Storage Over 30 Days and Winterized Storage	<ul style="list-style-type: none"> (1) Empty fuel tank (2) Turn off fuel valve (3) Disconnect the spark plug (4) Add 5ml of fresh oil to the cylinder and pull starter once to distribute oil (5) Treat metal parts with water-repellant, anti-corrosion product. (6) Store in dry, ventilated area

This is a suggested maintenance schedule. Depending on terrain, the schedule may need to be adjusted for dusty/rough conditions.

Troubleshooting

Problem	Causes	Corrective Action
Engine will not turn over	(1) Engine Brake Handle released (2) Incorrect fuel level (3) Obstruction under deck	(1) Operate Engine Brake Handle (2) Check fuel level (3) Remove obstruction
Engine smokes	(1) Incorrect fuel mix (2) Air cleaner oil-soaked or blocked	(1) Replace fuel mix (2) Service air cleaner
Engine runs then stops	(1) Fuel starvation (2) Fuel cap vent blocked	(1) Fill fuel tank (2) Clean fuel cap assy
Engine will not start	(1) Engine under load (2) Incorrect/contaminated fuel (3) Spark plug lead disconnected (4) Engine Brake Handle not released (5) Faulty spark plug or coil (6) Faulty wiring	(1) Raise height of cut (2) Drain tank and fill with correct / clean fuel (3) Connect spark plug lead (4) Release Engine Brake Handle (5) Clean/adjust/replace plug or coil (6) Check wiring
Engine runs rough	(1) Spark plug lead becoming disconnected during use (2) Faulty spark plug (3) Air cleaner blocked (4) Incorrect/contaminated fuel	(1) Connect spark plug lead (2) Clean/adjust/replace plug (3) Service air cleaner (4) Drain tank and fill with correct fuel
Engine vibrate excessively	(1) Disc Securing Bolt loose (2) Blade Retaining Bolts lose (3) Cutting system out of balance (4) Bent crankshaft	(1) Tighten/replace bolt (2) Tighten/replace bolts (3) Balance/replace cutting system (4) Contact your Honda Certified Dealer
Uneven cut	(1) Cutting system out of balance	(1) Balance/replace cutting system
Poor hovering	(1) Engine running slow (2) Impeller air vents blocked (3) Underdeck not clean (4) Cutting system loose	(1) Contact your Honda Certified Dealer (2) Check and unblock (3) Clean (4) Tighten cutting system or replace Disc Securing Bolt.

Mower Diagram

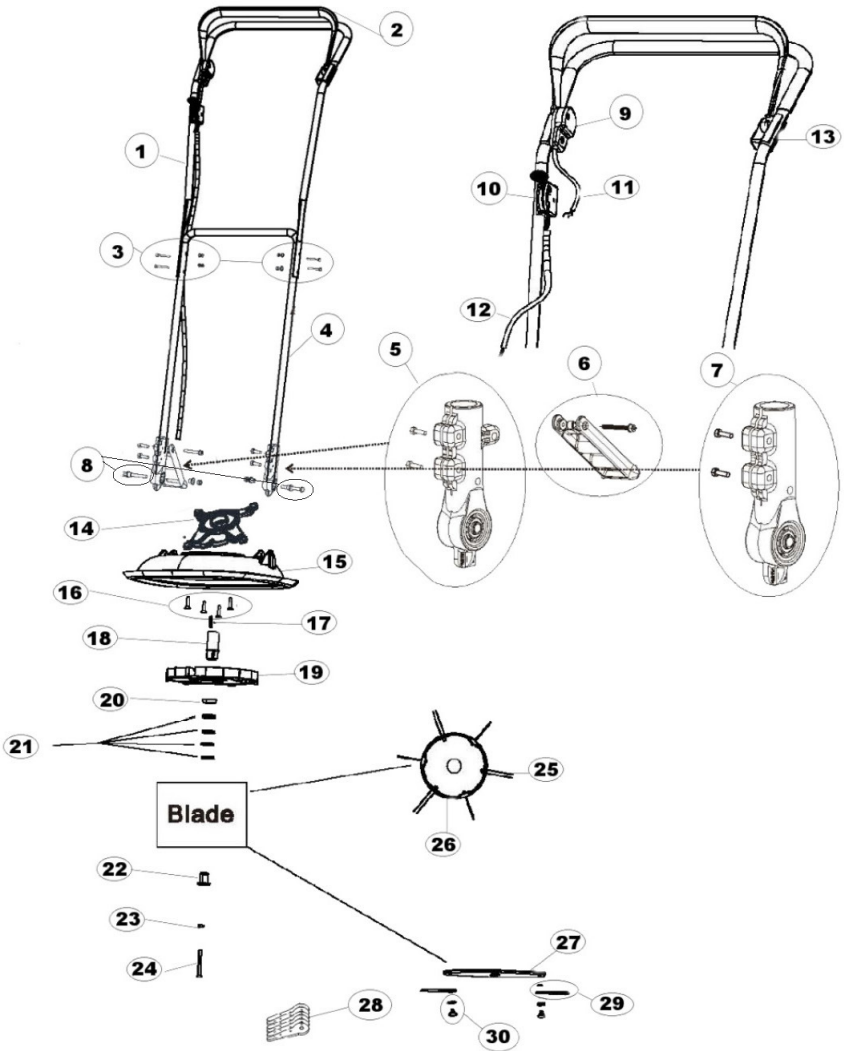

Mower Parts List

Key	Part No.	Description	Qty.	Notes
1	AF1500	Upper Handle	1	
2	AF1501	Cut Off Handle	1	
3	AF1507	Handle Securing Kit (Connects upper and lower handles)	1	
4	AF1545	Lower handle - NSH	1	
5	AF1542	Lower handle support (Footstop side) - NSH		
6	AF1543	Footstop - New style handle	1	
7	AF1544	Lower handle support (Left side) - NSH		
8	AF1510	Deck/Handle Kit (2 per kit)	1	
9	AF1503	Box with Spring	1	
10	AF1505	Throttle Control Lever & Box	1	
11	AF1504	Shutoff Cable	1	
12	AF1506	Throttle Cable	1	
13	AF1502	Shutoff Clip	1	
14	AF094	Engine Frame (New Style)	1	
15	AF1513	Deck	1	
16	AF1514	Deck to Frame Kit (4 per kit)	1	
17	AF1536	Woodruff key	1	
18	AF1529	Drive Hub	1	
19	AF1516	Impeller	1	
20	AF1517	Large Spacer	1	
21	AF1518	Shaft Spacer Kit (4 per kit)	1	
22	AF1520	Spigot	1	
23	AF1521	Disc Securing Washer	1	
24	AF1530	Disc Securing Bolt M8 X 70	1	
25	SE02214	Flexiblade Cutting Line	1	85' roll
26	AF1527	String Line Holder	1	
27	AF1519	Blade System Disc	1	
28	SE00603	QC Blade Kit (6 per kit)	1	
	SE01206	QC Blade Kit (kit of 60)	1	
29	SE02412	SS Blade Kit (3 per kit)	1	w/ washers
30	SE18370	Bolt Kit (3 per kit)	1	w/ washers
*	AF1512	Engine to Frame Securing Kit	1	Not Shown
*	AF1523	Cable Ties	2	Not Shown
*	JN-60	Engine	1	Not Shown
*	AF1524	Air Force Decal	1	Not Shown
*	AF1533	Fuel Ratio Decal	1	Not Shown
*	AF1230	Safety Decal	1	Not Shown
*	AF1231	Caution Decal	1	Not Shown
*	AF1525	QC Kit Complete	1	Not Shown
*	AF1526	SS Kit Complete	1	Not Shown

Engine Diagram

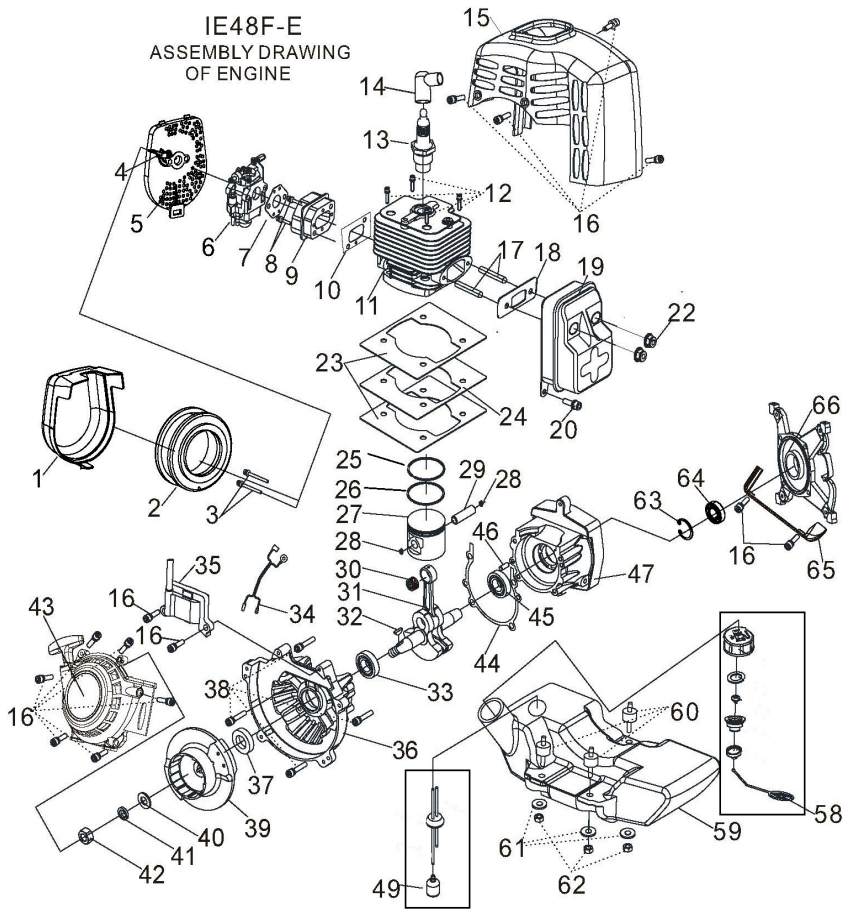

*(Not Shown) AF-200 Cylinder Assembly (Parts 11, 12 and 23-46)

Engine Parts List

No.	Key	Description	Qty
1	AF-080	Outside Cover	1
2	AF-003	Air Filter	1
3	AF-004	BoltM5*50	2
4	AF-081	Choke	1
5	AF-082	Inside Cover	1
6	AF-007	Carburetor	1
7	AF-008	Gasket	1
8	AF-009	ScrewM5*30	2
9	AF-010	Admitting Pipe	1
10	AF-011	Gasket	1
11	AF-025	Cylinder	1
12	AF-083	Cylinder Screw	4
13	AF-014	Spark Plug	1
14	AF-084	Cap	1
15	AF-085	Guide Cover	1
16	AF-015	ScrewM5*20	4
17	AF-086	Lead Screw	2
18	AF-087	Gasket	1
19	AF-022	Muffler	1
20	AF-024	ScrewM5*12	1
22	AF-072	Nut M5	2
23	AF-026	Gasket	2
24	AF-027	Gasket	1
25	AF-028	Upper Piston Ring	1
26	AF-029	Lower Piston Ring	1
27	AF-030	Piston	1
28	AF-031	Ring	2
29	AF-032	Piston Pin	1

No.	Key	Description	Qty
30	AF-033	Bearing	1
31	AF-034	Crank Shaft	1
32	AF-035	Key	1
33	AF-038	Bearing 6202	1
34	AF-043	Cord	1
35	AF-096	Coil	1
36	AF-039	Crank Case Cover	1
37	AF-040	Oil Seal	1
38	AF-041	Screw M5*30	4
39	AF-097	Fly Wheel	1
40	AF-045	Flat Washer 10	1
41	AF-046	Spring Washer 10	1
42	AF-047	Nut M10*1.25	1
43	AF-089	Pull Starter	1
44	AF-037	Gasket	1
45	AF-070	Bearing 6003	1
46	AF-036	Pin	1
47	AF-064	Crank Case	1
49	AF-090	Fuel Pipe/Plug/ Filter/Assy	1
58	AF-058	Cap Assy	1
59	AF-054	Fuel Tank	1
60	AF-055	Rubber Pillar	3
61	AF-053	Washer	3
62	AF-071	Nut M5	3
63	AF-069	Snap Ring	1
64	AF-092	Oil Seal	1
65	AF-093	Seal Block	1
66	AF-094	Engine Frame	1

Machine Notes

Seago's Mission Statement

Seago will serve the golf, sports turf, landscape and consumer markets with the goal to provide the finest specialized turf care equipment and customer service to all customers and potential customers, dealers and end users. The equipment we manufacture will be made from top quality materials and assembled in a correct and precise manner. The equipment we distribute from other manufacturers will be backed like it was our own. Seago's customer service will be defined by providing accurate and timely information to dealers, customers and potential customers. We will respond to their needs and questions accurately and truthfully while treating them with respect and delivering on our commitments.

To Our Dealers:

All orders will be shipped in an accurate and timely manner. We will provide you with any and all information necessary to help your customers choose our products. We will have in stock, or get as quickly as possible; all parts necessary to keep our equipment in top condition. We will respond to your requests within 24 hours and work with you to resolve any issues as quickly as possible.

To Our Employees:

Seago will be a stable, safe and enjoyable place to work. You will be valued as a team member. Creativity and suggestions for improvements will be encouraged. We will grow together.

To Our End Users:

All of Seago's equipment will be in top condition when delivered. We will stand behind all promises and warranties.

To Potential Customers:

Seago will provide you with the most information possible about the machine(s) you are interested in purchasing so that you can make an informed decision. We will not be a high pressure sales organization.

To Our Vendors:

Seago will pay our bills on time. We will work with you in the true spirit of a partnership to exceed our customer's expectations.

Machine Code:
Serial Number:

AIRFORCE HOVER MOWER

WARRANTY REGISTRATION

**THIS CARD MUST BE COMPLETED AND
RETURNED TO REGISTER YOUR MACHINE**

Course/Business Name:

Address:

Phone:

Contact Person:

Purchase Date:

Email:

Dealer Name:

Dealer Location:

Sales Representative:

DATA PROTECTION:

By submitting this form to Seago International, you are authorizing Seago to hold your information for future warranty and future sales/marketing promotional. The information on this card will be held and used by Seago International, Inc. only. No information on this card will be sold or distributed to a third-party for any reason.

Fax Registration to: 828-322-8511

Online Registration: www.seagointernational.com/warranty-app