



# AIR FORCE HOVER MOWER

Owner's Manual

**F-19 GEN 3**

JUNE 2026

Start: S/N AF19-18100



# Table of Contents

<b>Contents</b>	<b>3</b>	<b>Mower Parts List</b>	<b>18</b>
<b>Specifications</b>	<b>4</b>	<b>Mower Exploded Diagram</b>	<b>19</b>
<b>Introduction</b>	<b>5</b>	<b>Operating the Machine</b>	<b>20-21</b>
		Starting the Machine	20
<b>Warranty Information</b>	<b>6</b>	Cutting Flat Landscapes	21
		Cutting Slopes and Banks	21
<b>Safety Symbols</b>	<b>7</b>	Stopping the Machine	21
		Cutting Height Adjustment	21
<b>Safety Precautions</b>	<b>8</b>		
Training	8	<b>Machine &amp; Engine Maintenance</b>	<b>22-25</b>
Preparation	8-9	Engine diagrams	22
Operation	9-10	Cleaning the Air Filter	22
Maintenance & Storage	10-11	Servicing the Spark Plug	22
		Muffler	23
<b>Machine Assembly</b>	<b>12</b>	Oil Maintenance	23
		Keeping the Engine Clean	23
<b>Fuel &amp; Oil Recommendations</b>	<b>12</b>	Deck Housing	23
Oil Type	12	Nuts and Bolts	23
Fuel Type	12	Cutting System Maintenance	24
		Sharpening the SS Blades	24
<b>Before Starting the Machine</b>	<b>13</b>	Flexiblade Cutting System	25
Prevent Engine Damage	13	Mower Storage	25
Oil Level Check	13		
Fueling the tank	13	<b>Maintenance Schedule</b>	<b>26</b>
<b>Engine Exploded Diagram</b>	<b>14-15</b>	<b>Troubleshooting</b>	<b>27</b>
<b>Engine Parts List</b>	<b>16-17</b>	<b>Warranty Registration</b>	<b>Back Page</b>

# Specifications

## Main Features:

- (1) Padded handles
- (2) Positive pressure keeps OPC locked in place
- (3) 53" Handle for longer reach
- (4) Heavy gauge steel handles
- (5) Double tall air filter
- (6) Extra thick handle mounts
- (7) Nylon injected Polymer deck
- (8) 14" Impeller for increased lift



<b>Model</b>	F-19
<b>Engine</b>	Ducar
<b>Engine Type</b>	DVO-150
<b>Engine Speed</b>	3600 rpm
<b>Fuel Type</b>	Unleaded
<b>Fuel Capacity</b>	0.24 gallons
<b>Engine Oil Type</b>	SAE 10W-30
<b>Oil Sump Capacity</b>	0.5 quarts
<b>Cutting Width</b>	19 inches
<b>Dry Weight</b>	33 lbs

# Introduction

Thank you for purchasing the Air Force Hover Mower. The following pages are to give you information about maintenance, operation, safety and specifications instructions regarding your new mower. We strongly recommend reading the manual before your first use.

*Important: Familiarize yourself with all controls, operations and regular maintenance points before your first use. If you require clarification, please consult your local Authorized Dealer who can assist you further.*

The Air Force Hover Mower is designed for cutting grass and low-to-the-ground vegetation. Any other use is considered contrary to the intended use of the machine. Strict adherence and compliance with the conditions of operation, repair and service as stated in this manual are required. Precautions and safety tips found in this manual are standards that are generally recognized and must be observed at all times. Any modifications to this machine will relieve the manufacturer of liability for any resulting damage or injury.

Air Force Hover Mowers should only be operated, repaired or serviced by persons knowledgeable about the machines and familiar with their safety features. Correct operation and maintenance will ensure a long service of the machine.

All references to the left and right side of the machine are as viewed from behind the mower in the operator's position.

This manual is written based on information available at the time of publications. Air Force reserves the right to amend the product, specifications, and information within the manual without prior notification.

# Warranty

## LIMITED WARRANTY

The manufacturer warrants to the original purchaser that this unit shall be free from defect in material and workmanship under normal use and service for a period of **one year** from the date of purchase. The engine carries a 90 day commercial warranty.

To qualify for the full benefit of the Air Force warranty, the warranty registration card must be returned to the distributor. If your selling dealer does not offer this service, please fill out and return the enclosed warranty registration card. Subject to the conditions and exclusions noted in the Limited Warranty, we shall at our option, repair or replace any warranty part during the applicable period. If you are in doubt or experience any difficulty, please consult your Authorized Dealer for clarification.

A 90-day warranty period applies to those items which are subject to normal wear and tear: blade systems, cables, etc.

This warranty does not apply to any unit that has been tampered with, altered, misused, abused or used for hire, and will become invalid if non-genuine parts are fitted at any time. This warranty does not cover minor mechanical adjustments unless they are due to defective material or workmanship. Consult the Owner's Manual or your Authorized Dealer for assistance when making these adjustments.

To make a warranty claim, contact your Authorized Dealer with your proof of purchase, which states the machine serial number and date of purchase. The dealer will, at our option, repair or replace any warranty part within the duration of the warranty period. If your dealer does not provide services, please contact the distributor directly with your proof of purchase.

This limited warranty gives you specific legal rights and is in addition to any statutory rights to which you may be entitled; your statutory rights are not affected by this warranty.

**US / CANADA ONLY:** Information regarding Authorized Dealers can be obtained by contacting Seago International.

Web: [www.seagousa.com](http://www.seagousa.com)

Phone: (800) 780-9889

# Safety Symbols

**Manual:** Read the instruction manual before using machine.



**Use the Manual:** Refer to the manual when making any adjustments or repairs to the machine.



**Spark Plug:** Disconnect the spark plug when doing any work on the machine.



**Hot Surface:** Be aware of the hot surfaces of your machine during and after use.



**Protective Gear:** Always wear protective ear and eye gear when operating the machine.



**Safe Distancing:** Keep a safe distance of pedestrians and pets while the machine is in operation due to flying debris.

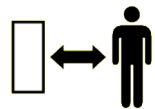

**Safe Footing:** Be aware of your footing and wear the proper footwear when operating the machine on an incline.



**Warning:** Always be alert of possible hazards and your work environment.



# Safety Precautions

Your machine is perfectly safe if used correctly. Failure to observe the following precautions may result in serious injury.

## Training

Read the Owner's Manual and other informational material that came with your new mower. If the operator or mechanic cannot read English, it is the owner's responsibility to explain this material to them.

Become familiar with the safe operation of the mower, operator controls, and safety signs.

All operators and mechanics should be trained. The owner is responsible for training all users.

The owner/operator is responsible for and can prevent accidents or injuries occurring to themselves, others and property by adhering to the safety instructions in this manual.

Never let children or untrained people operate or service the mower. Local regulations may restrict the age of the operator.

## Preparation

While using the machine, always wear substantial protective footwear and long pants. Do not operate the equipment when barefoot or wearing open-toe shoes.

Wear appropriate clothing including hard hat, safety glasses and hearing protection. Long hair, loose clothing or jewelry may get tangled in moving parts.

Any person within 6 feet of machine should wear protective clothing to prevent injury,

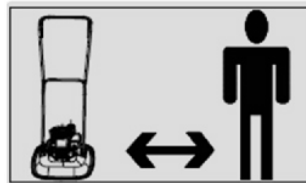

Evaluate the terrain to determine what accessories and attachments are needed to properly and safely perform the job. Only use accessories and attachments approved by Air Force.

Inspect the area where the equipment is to be used and remove all objects such as rocks, toys, and wire which can be thrown by the machine.

# Safety Precautions

Use extra care when handling gasoline and other flammable fuels. Vapors are explosive.

- (a) Use only approved fuel containers
- (b) Never remove fuel cap or add fuel when the engine is operating
- (c) DO NOT SMOKE while operating the machine
- (d) Never refuel or drain the machine indoors
- (e) Always use fresh non-ethanol fuel. Stale fuel can block the carburetor and cause leaks.

Check that the Operator Presence Control (OPC) and safety switches are attached and functioning properly.

Keep all parts in good working condition and all hardware tightened. Replace all worn or damaged decals.

Do not use near children or pets.

A damaged cutting device and/or impeller must be replaced. Before use, always visually inspect the cutting system to ensure that it is in good condition. Do not operate with an out-of-balance cutting system or impeller.

## **Operation**

Do not operate the engine in an enclosed space where exhaust fumes (carbon monoxide) can collect. Refuel outdoors only and do not smoke while refueling.

Do not operate the machine under the influence of alcohol or drugs.

Always pull the starter cord slowly until resistance is felt. Then pull the cord rapidly to avoid kickback and prevent hand or arm injury. Ensure that feet are away from the cutting system.

Operate only in daylight or good artificial light, keeping away from holes and hidden hazards.

Avoid operating the machine in wet grass. Be sure of your footing while using this product, especially when backing up. Reduced footing could cause slipping.

Walk, never run when operating the Air Force Hover Mower.

# Safety Precautions

Operate across the face of slopes, never up and down. Slow down and use extra care when making turns or changing direction on slopes. Be sure to travel in the recommended direction on slopes. Turf conditions can affect the machine's stability. Use caution while operating near drop-offs.

Never raise the deck with the blades in motion. Stop the engine before moving the machine across areas other than grass.

Never operate without the safety guards in place.

Do not change the engine governor settings or over speed the engine.

Never touch the exhaust/exhaust guard or cooling fins with the engine is hot.

## ***Stop engine and disconnect the park plug lead:***

- (1) Before clearing blockages
- (2) Before cleaning, checking or working on the machine
- (3) After striking a foreign object. Inspect the machine for damage and ensure necessary repairs are made before re-starting
- (4) If the machine starts to vibrate abnormally (check immediately).  
An out of balance cutting device causes severe vibration.

## ***Stop engine:***

- (1) Whenever you leave the machine
- (2) Before refueling
- (3) Before cleaning between the engine and impeller

Keep hands and feet away from the cutting system.

To start, machine should ONLY be on flat ground, clear of debris.

Do not start on tables, carts, vehicles, utility work spaces, etc.

## **Maintenance & Storage**

Disengage the drive, stop the engine and disconnect the spark plug. Wait for all movement to stop before adjusting, cleaning or repairing. Keep hands and feet away from moving parts.

Clean the cutting system, drive, muffler and engine of any grass or debris to prevent fires. Clean up any fuel/oil spills.

Never store machine with gasoline in the tank within an enclosed area where fumes may reach an open flame or spark.

# Safety Precautions

Park the machine on level ground. Never allow untrained persons to service the machine.

Remove the spark plug before attempting any repairs. Never check for a spark when the spark plug is removed. Use an approved tester.

Keep all parts in good working condition and all hardware tightened. Replace all worn or damaged decals. Always replace worn or faulty parts with genuine Air Force Hover Mower parts.

Allow the engine to cool before storing in any enclosures. To reduce the risk of fire hazard, keep the engine and the surrounding deck area free of grass, leaves, and excessive grease.

Shut off fuel while storing or transporting. Do not store fuel near flames or drain indoors.

If the fuel tank has to be drained, this should be done outdoors and when the engine is cool.

Wear strong work gloves when removing and reassembling the cutting device. Serious personal injury can occur without proper handling.



Never replace the cutting mechanisms with metal parts and only use cutting mechanisms which are suitable for use at the operating speed of the machine.

Never start the engine with the air filter or the air filter cover removed.

# Machine Assembly

## Assembling the Machine

### ***Step One: Lower Handlebar Assembly***

To fit the lower handle to both sides, align the holes (footstop on the right side) and insert the sleeves, bushes, bolts, washers and nuts as shown. (Uses Deck/Handle Kit AF1210)

### ***Step Two: Upper Handle Assembly***

To fit the upper handle on both sides, align the holes and fit the bolts and nuts. (Handle Securing Kit AF1207)

## FUEL AND OIL RECOMMENDATIONS

### **Oil Type**

When operating the Air Force Hover Mower, always use a high-quality synthetic oil. Suggested classification is **SAE 10W-30**. Additives are not recommended. To prolong the life of your engine, change the oil after the initial first five hours of use.

### **Fuel Type**

Clean, non-ethanol fuel is recommended. Purchase fuel in a 30-day quantity to keep fresh fuel on hand.

# Before Starting the Machine

## Prevent Engine Damage

To prevent damage to the engine, the machine is shipped without any fluids. The engine must be filled with the correct grade of oil and fuel before starting the engine.

## Oil Level Check

When checking the oil, keep the mower on a level surface. Remove the oil cap, and wipe the dipstick with a clean cloth. Reinsert the dipstick without screwing the cap back on, and remove it to check the oil level.

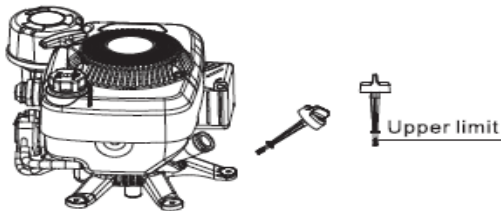

Correct oil level is when the brim of the liquid is at the **UPPER LIMIT** mark on the dipstick. Do not overfill the engine with oil.

## Fueling the tank

*Fill to the base of the neck to allow for fuel expansion. Do not overfill the fuel tank.*

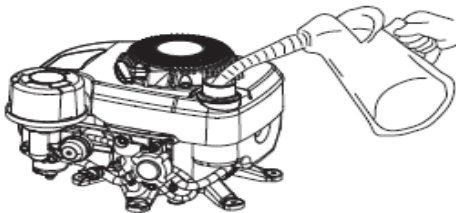

Ensure that the Operator Presence Control (OPC) Bail Arm moves freely and returns to its resting position when released.

# Exploded Engine Diagram

## DV0-150 CPC

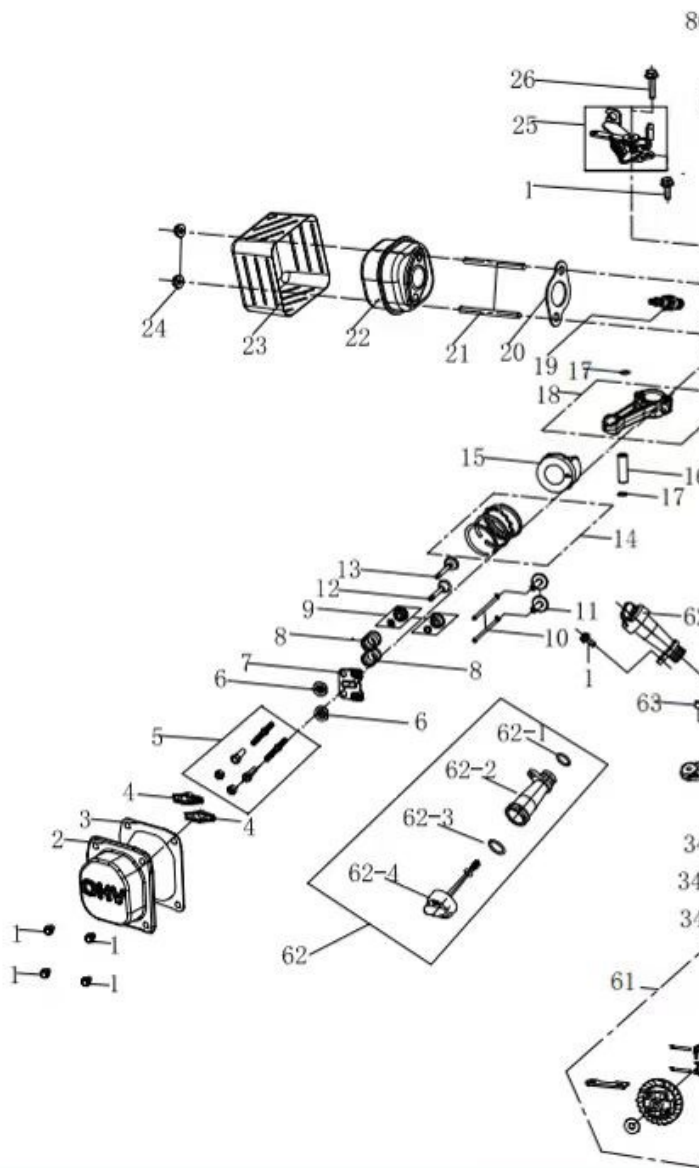

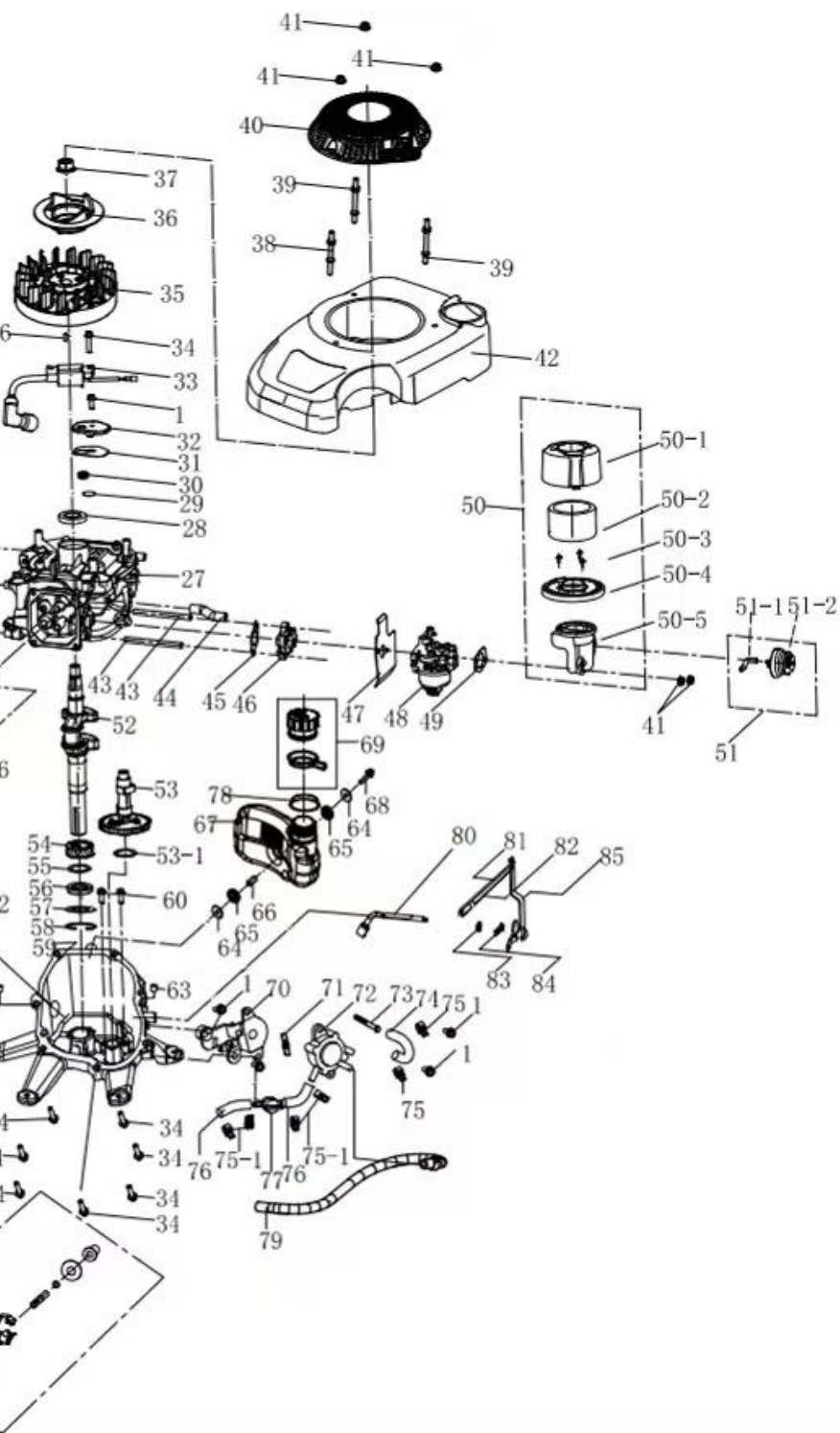

# Engine Part List

NO	PART	Part name	Quantity
1	AF901	BOLT M6X16	11
2	AF902	CYLINDER HEAD COVER	1
3	AF903	CYLINDER HEAD COVER GASKET	1
4	AF904	ROCKER ARM ( SET OF 2)	1
5	AF905	ROCKER ARM FASTENING BOLT ASSY (SET OF 2)	1
6	AF906	INLET VALVE SPRING SEAT (SET OF 2)	1
7	AF907	LIMIT PLATE ASSY	1
8	AF908	VALVE SPRINGS (SET OF 2)	1
9	AF909	INLET VALVE SPRING SEAT (SET OF 2)	1
10	AF910	THE VALVE PUSH ROD (SET OF 2)	1
11	AF911	THE VALVE LIFTER (SET OF 2)	1
12	AF912	INTAKE VALVE	1
13	AF913	EXHAUST VALVE	1
14	AF914	PISTON RING ASSY ( SET OF 5)	1
15	AF915	PISTON	1
16	AF916	PISTON PIN	1
17	AF917	PISTON PIN RETAINER (SET OF 2)	1
18	AF918	CONNECTING ROD COMPONENT	1
19	AF919	SPARK PLUG	1
20	AF920	EXHAUST GASKET	1
21	AF921	BOLT. STUD M6*77 (SET OF 2)	1
22	AF922	MUFFLER	1
23	AF923	MUFFLER HOUSING	1
24	AF924	LOCK NUT M6 (SET OF 2)	1
25	AF925	BRAKE ASSY	1
26	AF926	BOLT M6X18	1
27	AF927	CRANKSHAFT BOX BODY	1
28	AF928	CRANKSHAFT OIL SEAL	1
29	AF929	CIRCULAR PLATE	1
30	AF930	BREATHING VALVE SPRING	1
31	AF931	OIL RETURN CHAMBER COVER GASKET	1
32	AF932	OIL CHAMBER RETAINING PLATE	1
33	AF933	COIL	1
34	AF934	ENGINE BLOCK BOLT M6X25	8
35	AF935	FLYWHEEL	1
36	AF936	STARTER CUP	1
37	AF937	NUT M12X1.2 5	1
38	AF938	BOLT STUD.IGNITION COIL	1
39	AF939	STARTER COVER STUD (SET OF 2)	1
40	AF940	STARTER ASSEMBLY	1
41	AF941	NUT M6	5
42	AF942	ENGINE COVER	1
43	AF943	STUD M6X100 ( SET OF 2)	1
44	AF944	EXHAUST PIPE	1
45	AF1001	NEW INTAKE GASKET	1
46	AF1002	NEW HEAT INSULATION BLOCK	1
47	AF947	CARBURETOR GASKET	1
48	AF948	CARBURETOR ASSEMBLY	1

# Engine Part List

NO	PART	Part name	Quantity
49	AF949	AIR FILTER GASKET	1
50	AF950	AIR FILTER ASSEMBLY	1
50-1	AF951	AIR FILTER COVER	1
50-2	AF952	AIR FILTER	1
50-3	AF953	SCREW	3
50-4	AF954	AIR FILTER MIDDLE BRACKET	1
50-5	AF1003	NEW AIR FILTER LOWER BRACKET	1
51	AF956	PRIMER PUMP ASSY (PIPE AND PUMP)	1
52	AF957	CRANKSHAFT	1
53	AF958	CRANKSHAFT ASSEMBLY	1
53-1	AF959	CRANKSHAFT WASHER $\Phi 14.2 \times \Phi 21 \times 0.5$	1
54	AF960	CRANKSHAFT TIMING DRIVING GEAR	1
55	AF961	CRANKSHAFT WASHER $\Phi 25.5 \times \Phi 35 \times 1$	1
56	AF962	CRANKSHAFT OIL SEAL	1
57	AF963	OIL SEAL RETAINING WASHER	1
58	AF964	CLIP, FUEL LINE	1
59	AF965	CRANKCASE COVER / ENGINE FRAME	1
60	AF966	BOLT M6X12 (SET OF 2)	1
61	AF967	CENTRIFUGAL GOVERNOR GEAR ASSY	1
62	AF968	OIL GAUGE ASSY (62-1 THRU 62-4)	1
62-1	AF969	O-RING 22* $\Phi$ 2.5	1
62-2	AF970	OIL DIPSTICK OUTSIDE COVER	1
62-3	AF971	O-RING 26* $\Phi$ 2.7	1
62-4	AF972	OIL DIPSTICK	1
63	AF973	POSITIONING PIN OF CRANKCASE (SET OF 2)	1
64	AF974	WASHER, FUEL TANK (SET OF 2)	1
65	AF975	VIBRATION ISOLATION PAD (SET OF 2)	1
66	AF976	FUEL TANK BUSHING	1
67	AF977	FUEL TANK	1
68	AF978	BOLT M6X30	1
69	AF979	FUEL CAP ASSY	1
70	AF980	SPEED REGULATOR	1
71	AF981	SPEED REGULATING SPRING B	1
72	AF982	FUEL PUMP	1
73	AF983	FUEL FILTER	1
74	AF984	FUEL PIPE HOSE (p6.3x(p10x135 EPA	1
75	AF985	FUEL PIPE CLAMP <P10	2
75-1	AF986	FUEL PIPE CLAMP 013 (SET OF 4)	1
76	AF987	FUEL PIPE (p6.3x(p12.7«50 EPA	2
77	AF988	FUEL COCK	1
78	AF989	TANK DAMPENING RING	1
79	AF990	AIR HOSE	1
80	AF991	SWINGING ROD	1
81	AF1004	NEW THROTTLE LEVER (7 1/8" LONG )	1
82	AF993	COIL SPRING	1
83	AF994	PENDULUM STEM SEAL	1
84	AF995	COTTER PIN	1
85	AF996	CONTROL ARM	1
86	AF1005	WOODRUFF KEY (INTERNAL) for DVO-150	1

## Mower Parts List

Key	Part No	Description	Qty	Notes
1	AF1200	Upper Handle	1	
2	AF1241	OPC brake handle	1	
3	AF1240	OPC lever holder	1	
4	AF1239	Brake box and cable	1	
5	AF1245	Lower handle	1	
6	AF1207	Handle securing kit	1	(Flange nuts & bolts)
7	AF1242	Handle Support RH	1	Footstop side
8	AF1243	Footstop w/ bolt	1	
9	AF1244	Handle support - LH	1	
10	AF1210	Deck/handle kit	1	Set of 2
11	AF1270	Deck/frame nut kit M6 G3	1	Set of 6
12	AF1271	Deck G3	1	
13	AF1272	Deck/frame bolt(M6 x 12.3)G3	1	Set of 6
14	AF1276	Woodruff key G3	1	
15	AF1217	Hub Spacer	1	
16	AF1273	Drive hub G3	1	
17	AF1274	Impeller G3	1	
18	AF1220	Large Spacer	1	
19	AF1221	Shaft spacer kit	1	Set of 3
20	AF1222	Blade system disc	1	
21	SE02412	SS blade kit w/ large washer	1	Set of 3 each
22	SE18370	Bolt kit w/ small washer	1	Set of 3 each
23	AF1225	Blade retaining spigot	1	
24	AF1226	Washer	1	
25	AF1275	Disc securing bolt G3	1	3/8*G24*75MM
26	SE00603	QC Blades	1	Set of 6
*	SE01206	QC Blades	1	Set of 60
27	SE04428	Flex blade roll 3.30mm	1	121 ft roll
28	AF1223	String system disc	1	
29	AF1250	Hi-Lift kit w/ clips	1	
30	AF1251	Hi-Lift clip only	1	
31	AF1264	Extension handle only	1	14in long
*	AF1260	Extension handle <b>kit</b>	1	#6,31 & cable
*	AF1263	Extended brake cable	1	Red box
*	DV0-150 CPC	Engine	1	Not Shown
*	AF1279	Air Force Decal G3	1	Not Shown
*	AF1230	Safety Decal	1	Not Shown
*	AF1231	Caution Decal	1	Not Shown
*	AF1232	QC Complete Disc		#20,22,26 (3)
*	AF1233	SS Complete Disc		#20,21,22
*	AF1280	Impeller Warning Decal	1	Not Shown

# Exploded Diagram

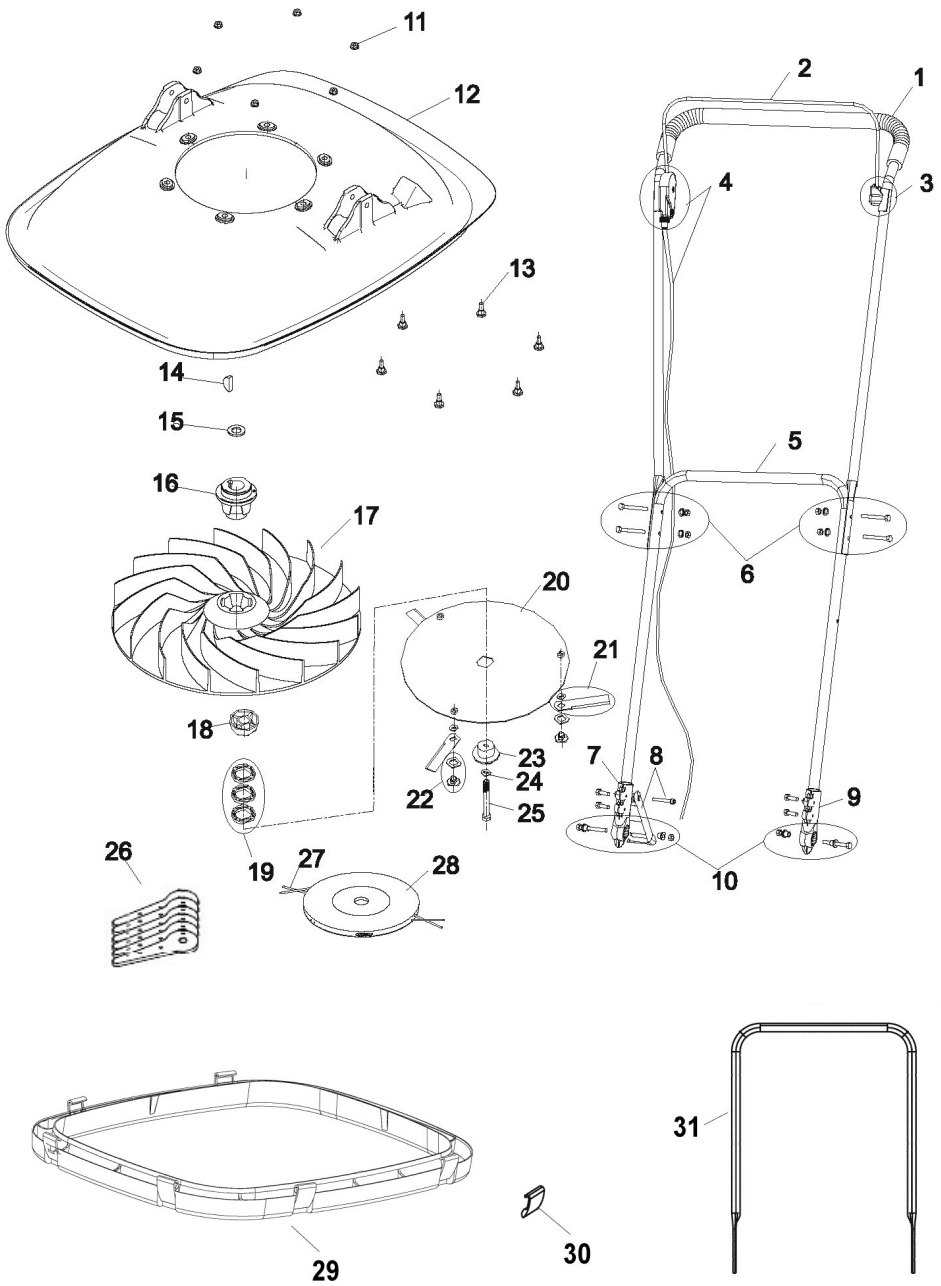

# Operating the Machine

## Starting the Machine

### **Step One:**

Turn the petcock to the “on” position.

### **Step Two:**

Press primer bulb NO MORE than 3 times.

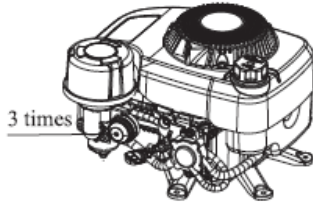

### **Step Three:**

Release the handlebar from the footstop. Hold the OPC Bail Arm to the upper handle, place your foot on the right side of the deck and slightly tilt the machine toward you. This position ensures the fuel is beginning to circulate and makes cranking the engine easy. If starting the engine in tall grass, you must slope the deck.

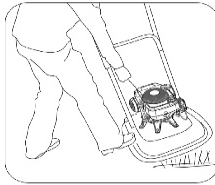

Pull the recoil starter rope lightly until you feel resistance, then pull briskly. Return the starter grip gently. Once started return choke to open position.

Note: The OPC Bail Arm must be held firmly against the handlebar to start and keep the engine running.

If it is released, the engine and blade system will stop.

*To prevent damage, never pull the engine start grip while the engine is running.*



# Operating the Machine

## Cutting Flat Landscapes

Begin at the edge of the lawn and mow in a straight line back and forth as you would with a regular walk behind machine.

**Caution:** *Never stand below or beside the machine while mowing an embankment. Always stand higher on the slope than the machine.*

## Cutting Slopes and Banks

Begin at the top and swing the machine from side to side while carefully and slowly moving down the slope. Keep the machine moving to reduce strain on the engine.

## Stopping the Machine

Release the OPC Bail Arm to stop the machine. If the engine fails to stop, pull the spark plug lead loose from the engine.

## Cutting Height Adjustment

Your machine is shipped with the cutting disc in the highest position. Follow these steps to adjust to the desired height of cut:

- (1) Turn the petcock to the “off” position.
- (2) Disconnect the spark plug.
- (3) Tilt the machine onto its left side, **keeping the carburetor up.**
- (4) Wearing protective hand gear, remove the Disc Securing Bolt with holding the cutting system.
- (5) Remove the three spacers and the cutting system.
- (6) Reposition the spacers and cutting system for desired height of cut.
- (7) Fit the Disc Securing Bolt back to the machine. ***Bolt should be installed to 18ft pounds of torque.***

**Note:** *Large spacer must be positioned directly below the impeller at all times.*

## Prevent An Accident

Inspect the cutting area before using the mower. Any objects other than grass and leaves should be removed to prevent them from becoming projectiles.

Inspect for hidden obstructions, which would cause health and safety risks when coming in contact with the cutting system. Make note of the obstructions and mow around them.

# Machine and Engine Maintenance

*To prevent accidents, disconnect the spark plug whenever you are performing any maintenance procedures on the machine.*

## Engine:

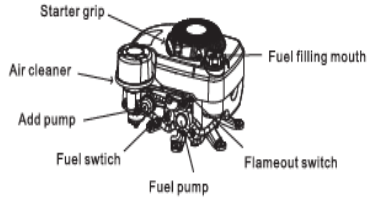
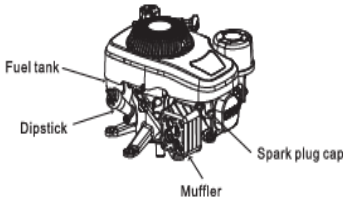

## Cleaning the Air Filter

The air filter should be cleaned every 8 hours, more often when used in a dusty environment. Engine power will be reduced if it is not cleaned properly. Do not use the machine if there is no air filter or if the filter is damaged. Failure to properly maintain the filter will void the warranty.

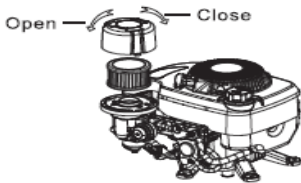

Clean the filter with compressed air. Clean the outside mesh frequently. If it's too dirty or damaged, replace.

*Do not brush or use fuel / oil to clean the air cleaner.*

After cleaning the air cleaner, return it back to the case, being sure to securely attach the cover.

## Servicing the Spark Plug

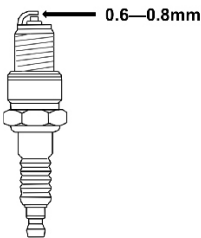

Use only an approved spark plug tester. Clean the spark plug every 25 hours. Use a steel brush to remove combustion residue. Calibrate the clearance between electrodes to 0.5-0.7mm with a feeler gauge. Replace the spark plug twice a year to avoid failure.

# Machine and Engine Maintenance

## Muffler

Check the muffler often to make sure it is not loose, damaged or rusty. Do not use the machine until the muffler is repaired or replaced.

\*\*Before starting the engine, check the two muffler bolts (#21, AF921) are tight. Loose muffler or cylinder may cause engine fire.

## Oil Maintenance

Before each use, check the oil level and ensure that a correct oil level is at the upper limit. Refer to the “Before Starting the Machine” section for instructions.

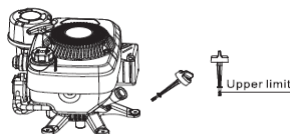

Change the oil after the initial first five (5) hours of use. Subsequently, change the oil every 50 hours or as needed.

- (1) Run the engine until the fuel tank is empty.
- (2) Remove the spark plug lead.
- (3) Allow the engine to cool.
- (4) Drain the oil while the engine is warm (not hot).
- (5) Tip the machine over on to its left side (*keeping the carburetor side up*).
- (6) Drain the oil into a suitable container.
- (7) Refill with a high grade SAE 10W-30 synthetic oil.

## Keeping the Engine Clean

Remove all debris and grass from the engine, including the exhaust and exhaust guard, air ways in the top cowl, and surrounding deck areas on a daily basis or after each use. Do not clean between engine & impeller while the engine is running. Do not pressure-wash the machine during cleaning. Water can contaminate the fuel. Always clean with a brush or compressed air.

Grass and debris may clog the engine’s air cooling system especially after prolonged operation or cutting tall, dry grass. The internal cooling fans and surfaces may require cleaning to prevent the engine from overheating.

## Deck Housing

Remove debris and grass from both sides of the deck immediately after each use.

## Nuts and Bolts

Check all securing nuts and bolts regularly to ensure they remain tight. Replace missing or damaged items immediately.

# Machine Maintenance

## Maintaining the Cutting System

The condition of the cutting system and supporting mounting system should be checked regularly for signs of wear or damage. A damaged cutting system will become out of balance and cause the machine to vibrate excessively. The cutting system could damage the deck, impeller and other pieces under the deck and lead to damage to the engine or the operator.

***DO NOT*** use a damaged / unbalanced cutting system. Replace the cutting system every two years or as wear and damage demand.

Regularly ensure the Disc Securing Bolt is tightened. Do not start machine on tables, carts, utility work spaces, vehicles, etc.

## Prevent An Accident

*Never work on the mower unless the spark plug lead has been removed. ALWAYS wear strong gloves to protect your hands from serious injury. ALWAYS use genuine parts.*

To replace the cutting system:

- (1) Drain the fuel by running the engine dry (engine will stop).
- (2) Remove the spark plug lead and allow the engine to cool.
- (3) Turn the machine on its left-hand side (***carburetor up***).

If you only need to replace the blades or the blade securing kit, you would not need to remove the cutting disc from the machine. If you need to replace the entire cutting disc or the spacers, the disc will need to be removed by first removing the Blade Retaining Bolt.

## Sharpening the Stainless Steel Blades

Our stainless steel blades are reversible and can be sharpened. You simply need to sharpen the sides when then they wear down. For best results, use both sides until they need to be sharpened, and then sharpen both sides at the same time.

Blades should be sharpened every 25 hours or as needed. Sharpen with a flat file for best results.

## Prevent An Accident

Remove the cutting blades from the cutting system before sharpening. Use strong gloves while handling the blades to prevent serious injury.



# Machine Maintenance

## Flexiblade Cutting System Replacement

- (1) Drain the fuel by running the engine dry (engine will stop).
- (2) Remove the spark plug lead and allow the engine to cool.
- (3) Turn the machine on its left-hand side (**carburetor up**).
- (4) Replace the old line with 10 inches of new line.

## Mower Storage

To prevent engine damage, engines must be drained of fuel when being stored in excess of 30 days. Removing the fuel prevents gum from forming in the fuel system and essential carburetor parts. By following our storage procedure and referring to the engine manual as needed, your machine will remain in good working order.

- (1) Drain the fuel by running the engine dry (engine will stop).
- (2) Disconnect the spark plug lead.
- (3) Change the engine oil.
- (4) Remove the engine spark plug, pour 0.5fl oz of engine oil into the machine cylinder, and replace the spark plug. Avoid engine damage by **not** exceeding the volume of oil. **Do not replace the spark plug lead.**
- (5) Slowly pull the recoil starter rope, turning the crankcase, to distribute oil and prevent engine corrosion.
- (6) Clean all debris and grass from the engine cylinder, cooling fans, under top cowl, and around and behind the exhaust / exhaust guard.
- (7) Lubricate the machine.
- (8) Treat metal parts with a water-repellant anti-corrosion product.
- (9) Cover the machine with a protective sheet and store it in a dry, ventilated area.

# Maintenance Schedule

Service Schedule	Maintenance
Before Each Use	<ol style="list-style-type: none"> <li>(1) Check the fuel and oil levels</li> <li>(2) Check blade system and tighten any loose bolts</li> <li>(3) Check air filter – ensure it is dry</li> <li>(4) Remove debris from the cutting system, impeller, and air intake area of engine</li> </ol>
Every Use	CLEAN THE AIR FILTER (Replace if needed)
Every 5 Hours	<ol style="list-style-type: none"> <li>(1) Change the engine oil</li> <li>(2) Clean the air filter</li> <li>(3) Inspect Plug</li> <li>(4) Sharpen cutting blades</li> </ol>
Every 20 Hours or Once a month	<ol style="list-style-type: none"> <li>(1) Tighten/replace any loose/damaged bolts, blades or cutting disc</li> <li>(2) Change the oil</li> </ol>
Every 50 Hours	<ol style="list-style-type: none"> <li>(1) Clean/replace air filter</li> <li>(2) Sharpen/replace blades</li> <li>(3) Clean/replace fuel filter</li> <li>(4) Check for any leaks or deteriorations in the fuel system and hoses</li> </ol>
Every 100 Hours	<ol style="list-style-type: none"> <li>(1) Replace the spark plug</li> <li>(2) Replace air cleaner &amp; filter</li> <li>(3) Clean the cooling system (fins/starter area)</li> </ol>
Storage Over 30 Days and Winterized Storage	<ol style="list-style-type: none"> <li>(1) Empty fuel and oil</li> <li>(2) Turn off fuel valve</li> <li>(3) Disconnect the spark plug</li> <li>(4) Add 15ml of fresh oil to the cylinder and pull starter once to distribute oil</li> <li>(5) Treat metal parts with water-repellant, anti-corrosion product.</li> <li>(6) Store in dry, ventilated area</li> </ol>

*This is a suggested maintenance schedule. Depending on terrain, the schedule may need to be adjusted for dusty/rough conditions.*

# Troubleshooting

<b>Problem</b>	<b>Causes</b>	<b>Corrective Action</b>
Engine will not turn over	(1) OPC Bail Arm released (2) Incorrect oil level (3) Obstruction under deck	(1) Operate OPC Bail Arm (2) Check oil level (3) Remove obstruction
Engine smokes	(1) Excess oil (2) Air cleaner oil-soaked or blocked	(1) Check oil level (2) Service air cleaner
Engine runs then stops	(1) Fuel starvation (2) Fuel cap vent blocked (3) Petcock closed	(1) Fill fuel tank (2) Clean fuel cap assy (3) Open petcock/fuel switch
Engine will not start	(1) Engine under load (2) Incorrect/contaminated fuel (3) Spark plug lead disconnected (4) OPC Bail Arm not released (5) Faulty spark plug (6) Faulty wiring	(1) Raise height of cut (2) Drain tank and fill with correct / clean fuel (3) Connect spark plug lead (4) Operate OPC Bail Arm (5) Clean/adjust/replace plug (6) Check wiring
Engine runs rough	(1) Spark plug lead becoming disconnected during use (2) Faulty spark plug  (3) Air cleaner blocked (4) Incorrect/contaminated fuel	(1) Connect spark plug lead  (2) Clean/adjust/replace plug (3) Service air cleaner (4) Drain tank and fill with correct fuel
Engine vibrate excessively	(1) Disc Securing Bolt loose (2) Blade Retaining Bolts loose (3) Cutting system out of balance (4) Bent crankshaft	(1) Tighten/replace bolt  (2) Tighten/replace bolts  (3) Balance/replace cutting system (4) Contact your Seago dealer
Uneven cut	(1) Cutting system out of balance	(1) Balance/replace cutting system
Poor hovering	(1) Engine running slow (2) Impeller air vents blocked (3) Underdeck not clean (4) Cutting system loose	(1) Contact your Seago Dealer (2) Check and unblock (3) Clean (4) Tighten cutting system or replace Disc Securing Bolt.

**Machine Code:**  
**Serial Number:**

# AIRFORCE

## HOVER MOWER

# WARRANTY REGISTRATION

**THIS CARD MUST BE COMPLETED AND  
RETURNED TO REGISTER YOUR MACHINE**

Course/Business Name:

Address:

Phone:

Contact Person:

Purchase Date:

Price Paid:

Email:

Dealer Name:

Dealer Location:

Sales Representative:

**DATA PROTECTION:**

By submitting this form to Seago International, you are authorizing Seago to hold your information for future warranty and future sales/marketing promotional. The information on this card will be held and used by Seago International, Inc. only. No information on this card will be sold or distributed to a third-party for any reason.

Fax Registration to: 828-322-8511

Online Registration: [www.seagointernational.com/warranty-app](http://www.seagointernational.com/warranty-app)