

GENERAL PURPOSE ENGINE

GXV57U

PARTS CATALOGUE

1

FOREWORD INDEX

1

ENGINE GROUP

2

PART NUMBER INDEX

3

PART NAME INDEX

4

Instruction for use of parts catalogue

- **This parts catalogue was prepared based on the latest information available as of December 20, 2006.**
- See the parts catalogue news for any revision that is made after December 20, 2006.
- **Always specify the part number when ordering a part.**
- Check the model, type, serial numbers, color, maker, and the size as needed before ordering a part.
- Note that the illustrations (part drawings) can differ from the actual parts in shape. They are given just to help you to refer to the parts.
- **When modifications or additions to this parts catalogue are made, a revised edition will be issued at an appropriate time, with successively progressing revision numbers on the cover. We recommend obtaining such revisions in order to keep your parts catalogue up-to-date at all times. To check whether a parts catalogue revision has been issued, please contact your Honda distributor.**

Initial version issue date **December 20, 2006**
Honda Motor Co., Ltd.

CONTENTS

	Page	Address No.	
● Instruction for use of parts catalogue	1	B 1	1
● How to refer to the part information	2	B 2	
● Part catalogue structure	3	B 3	
● When the parts were revised	4	B 4	
● Abbreviations used in the parts catalogue	4	B 4	
● How to check the part block and serial numbers	5	B 5	
● Models, parts catalogue codes and applicable serial numbers	6	B 6	
● Fuel hose, general purpose hoses and vinyl hose	7	B 7	
● FLAT RATE SERVICE TIME	8	B 8	
● Illustrated index	13	B13	
● ENGINE GROUP	15	C 1	2
● PART NO. INDEX	31	D 1	3
● PART NAME INDEX	32	E 1	4

How to refer to the part information

A Reference with "Illustrated index"

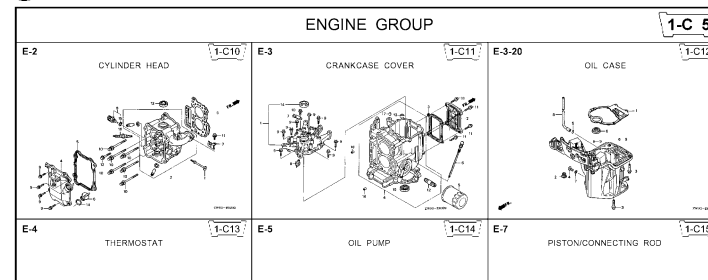

B Reference with "Part number index"

PART NO. INDEX

Part Number	Address	Page	Rel.	Part Number	Address	Page
06000				15212-ZW9-000	1-C14	3C
06316-ZW9-000	1-69	88	1	15220-ZW9-003	1-C14	3C
11000				15332-ZW9-000	1-E8	5E
11300-ZW9-405	1-C11	27	1	15352-ZW9-A30	1-E11	5E
11300-ZW9-406	1-C11	27	1	15400-PFB-004	1-C11	27
11340-ZW9-000	1-C11	27	2	15422-ZW9-000	1-C14	3C
11342-ZW9-000	1-C11	27	3	15473-881-000	1-C14	3C
11381-ZW9-003	1-C12	28	1	15474-ZW9-000	1-C14	3C
				15611-921-000	1-C10	2E
				15655-ZW9-000	1-C11	27
12000				16000		
12000-ZW9-405ZA	1-C11	27	4	16010-ZV4-005	1-D4	3E
12155-ZV4-A00	1-C13	29	1	16011-ZV4-005	1-D4	3E
12166-ZW9-000	1-C10	26	1	16013-ZW9-003	1-D4	3E
12209-GB4-681	1-C16	32	1	16016-ZW9-003	1-D4	3E
12210-ZW9-405ZA	1-C10	26	2	16016-ZW9-721	1-D4	3E
12216-ZE2-300	1-E8	58	1	16023-ZW9-003	1-D4	3E
	1-E11	58	1	16024-ZV4-650	1-D4	3E
				16028-ZV4-650	1-D4	3E

C Reference with "Part name index"

PART NAME INDEX

Part name	Address	Page	Ref.
[A]			
ABSORBER , FUEL	1-E15	62	5
ARMATURE COMP.	1-D11	43	7
ARM COMP. , LINK JOINT	1-G6	85	18
ARM COMP. , SHIFT LINK	1-G6	85	14
ARM COMP. , TILT	1-F15	79	20
ARM , FUEL PUMP ROCKER	1-C16	32	4
ARM , REVERSE LOCK	1-F15	79	18
ARM , SHIFT LINK	1-F11	74	7
ARM , STOPPER	1-D1	33	12
ARM , THROTTLE REMOTE	1-F11	74	6
ARM , VALVE ROCKER	1-C16	32	3
[B]			
BAG , TOOL , 160MM	1-G5	84	10
BAND	1-G6	86	37
BAND B1 , WIRE	1-F6	69	1
BAND , CORD	1-F3	67	18
BAND , TUBE CLIP , 11MM	1-E15	63	20
BAND , TUBE CLIP , 12.5MM	1-E15	63	19

Address No. 1-C10

E-2 CYLINDER HEAD

Block No.

Ref No.

Ref. No.	Part No.	Description	Reqd. QTY						Serial No.	Parts catalogue code
			99D1	99D1	1001	1001	1001	1001		
1	12166-ZW9-000	STOPPER, ENGINE SIDE	2	2	2	2	2	2		
2	12210-ZW9-000ZA	HEAD COMP., CYLINDER	1	1	1	1	1	1		
3	12251-ZW9-003	GASKET, CYLINDER HEAD	1	1	1	1	1	1		
4	12310-ZW9-000	COVER COMP., HEAD	1	1	1	1	1	1		
5	12312-ZW9-000	PACKING, HEAD COVER	1	1	1	1	1	1		
6	15611-921-000	CAP, OIL (NO GAUGE)	1	1	1	1	1	1		
7	16617-ZW9-000	HOLDER, CABLE	1	1	1	1	1	1	SC,SG	
	16617-ZW9-010		1	1	1	1	1	1	1001800 LHC,LHD	
			1	1	1	1	1	1	1001801 LHC,LHD	
8	35673-ZW5-003	SENSOR ASSY., WATER	1	1	1	1	1	1		
9	90003-ZW9-000	BOLT, FLANGE, 6X22	4	4	4	4	4	4		
10	90007-ZW9-003	BOLT, FLANGE, 8X83	6	6	6	6	6	6		
11	90011-ZW9-000	BOLT, FLANGE, 6X14 (CT200)	1	1	1	1	1	1		
12	90020-ZW9-000	BOLT, FLANGE, 8X40	2	2	2	2	2	2		
13	91202-KJ9-003	OIL SEAL, 20X32X6	1	1	1	1	1	1		
14	91301-805-000	O-RING, 26X2.7	1	1	1	1	1	1		
15	91307-PK2-005	O-RING, 9.5X1.5 (HONDA KIKAKI)	1	1	1	1	1	1		
16	98059-55916	PLUG, SPARK (CR5EH-9)	2	2	2	2	2	2		
	98059-55926	PLUG, SPARK (U16FER9)	2	2	2	2	2	2		

2006.09.20 E

Page No.

Part catalogue structure

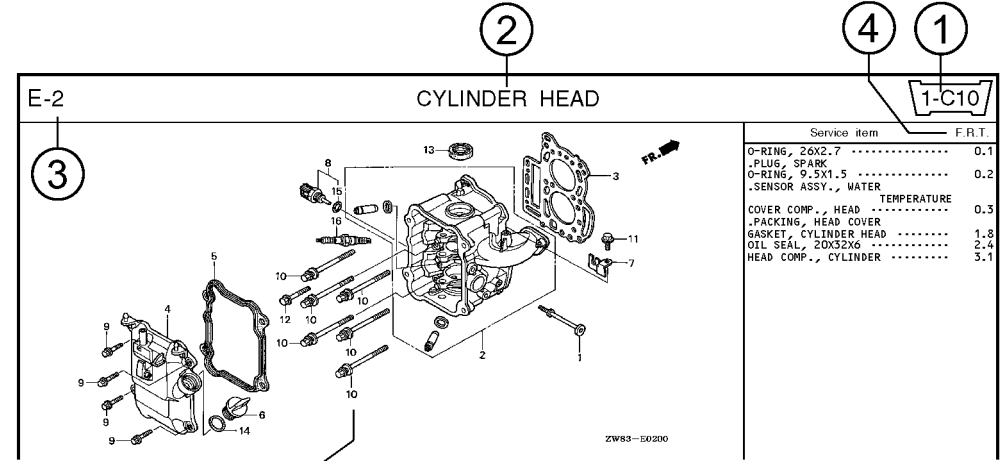

Ref. No.	Part No.	Description	Reqd. QTY						Serial No.	Parts catalogue code
			BF 9/901	BFP 9/901	BF 1001	BFP 1001	BF 1081	BFP 1081		
1	12166-zw9-000	STOPPER, ENGINE SIDE	2	2	2	2	2	2		
2	12210-zw9-000ZA	HEAD COMP., CYLINDER *NH8* DARK GRAY	1	1	1	1	1	1		
3	12251-zw9-003	GASKET, CYLINDER HEAD	1	1	1	1	1	1		
4	12310-zw9-000	COVER COMP., HEAD	1	1	1	1	1	1		
5	12312-zw9-000	PACKING, HEAD COVER	1	1	1	1	1	1		
6	15611-921-000	CAP, OIL (NO GAUGE)	1	1	1	1	1	1		
7	16617-zw9-000	HOLDER, CABLE	1	1	1	1	1	1	SC,S6	
	16617-zw9-010		1	1	1	1	1	1	1001800 LHC,LHD	

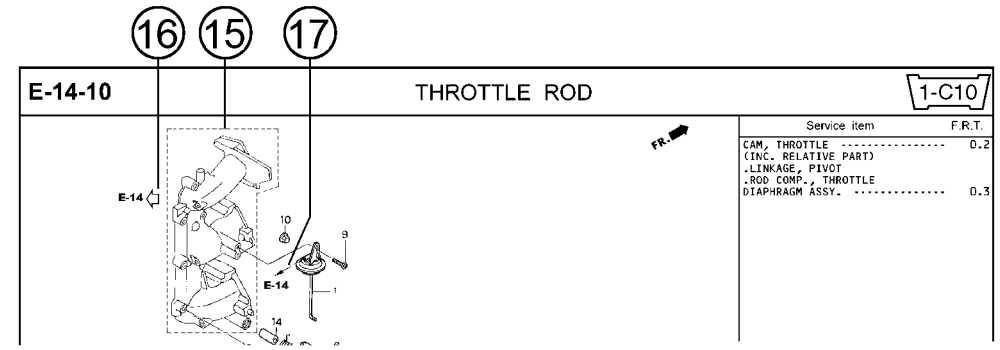

- ① **Address number**
 - Address No. is provided (in place of the page No.) to help you refer to the part with the part No. or part name.
- ② **Block title** ③ **Block number**
- ④ **Service item/Flat rate time**
- ⑤ **Reference number**
 - Title number marked with the parenthesis or parentheses indicates that it continues from the previous page.
- ⑥ **Part number** ⑦ **Honda color code**
- ⑧ **Description**
- ⑨ **Assemblies**
 - Sections framed with broken lines in the exploded view drawings are available as complete assemblies. (Their individual parts can also be obtained.)
- ⑩ **Color description**
- ⑪ **Note**
 - Notes are shown with the parentheses in the part name column.
- ⑫ **Required quantity**
 - Required QTY shown in the parenthesis or parentheses indicates the optional part.
 - Required QTY marked with "N" Indicates the optional part that should be selected as needed.
 - Required QTY indicates the number of the part used in the block.
- ⑬ **Serial number**
- ⑭ **Type**
 - When the type column is blank, it indicates that the part is applicable to all types.
 - As the type of the actual unit may differ from the "parts catalogue, type" please refer to "Models, types and applicable serial numbers" for confirmation.
- ⑮ **[Dotted box]**
 - Parts enclosed within a dotted line [] are covered in a different block.
- ⑯ **[Hollow arrow]**
 - A hollow arrow [] indicates the block No. for the parts enclosed within a dotted line [] .
- ⑰ **[Solid arrow]**
 - A solid arrow [] indicates the block No. the part in question is connected to.

When the parts were revised



Be sure to check the serial number!!



Ref. No.	Part No.	Description	Reqd. QTY						Serial No.
			BF 99D1	BFP 9.9D1	BF 10D1	BFP 10D1	BF 10B1	BFP 10B1	
1	12166-ZW9-000	STOPPER, ENGINE SIDE	2	2	2	2	2	2	
2	12210-ZW9-000ZA	HEAD COMP., CYLINDER *NH8*.....DARK GRAY	1	1	1	1	1	1	
3	12251-ZW9-003	GASKET, CYLINDER HEAD	1	1	1	1	1	1	
4	12310-ZW9-000	COVER COMP., HEAD	1	1	1	1	1	1	
5	12312-ZW9-000	PACKING, HEAD COVER	1	1	1	1	1	1	
6	15611-921-000	CAP, OIL (NO GAUGE)	1	1	1	1	1	1	
7	16617-ZW9-000	HOLDER, CABLE (###).....	1	1	1	1	1	1	SC, SG 1001800 LHC, LHD 1001801 LHC, LHD
	16617-ZW9-010	1	1	1	1	1	1	

The number has been used from the initial model without revision. When shown at the left side, it is applicable to the models of No.1001801 and the subsequent numbers. When shown at the right side, it is applicable to the models up to No.1001800.

• The parts listed with "###" at the end of the parts name have limited supply period (parts not for sale).

Abbreviations used in the parts catalogue

• The following abbreviations are used in the parts name column.

- A Ampere
- A.C. Alternating current
- ASSY. Assembly
- AT. Automatic transmission
- C.D.I. Capacitive discharge ignition
- COMP. ... Complete
- D.C. Direct current
- EX. Exhaust
- G.F.C.I ... Ground fault circuit interruptor
- HEX. Hexagonal
- H.S.T. Hydrostatic transmission
- FR.Front
- IN.Inlet
- L (100L) .Link (100 Links)
- L.Left
- MMMillimeter
- MT.Manual Transmission
- P.T.O.Power take off
- R.Right
- RR.Rear
- STD.Standard
- T (22T) ...Tooth (22 Teeth)
- VVolt
- WWatt

How to check the part block and serial numbers

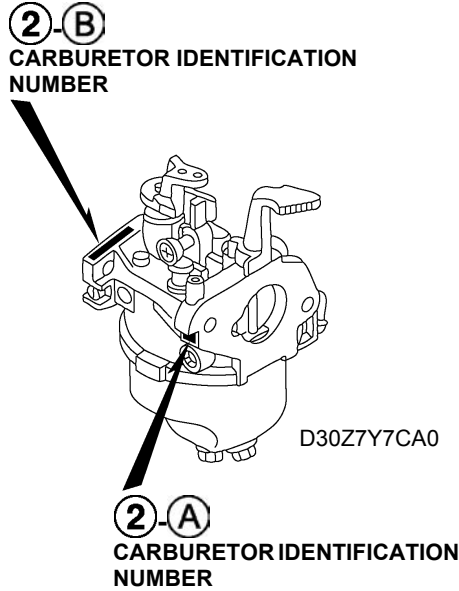
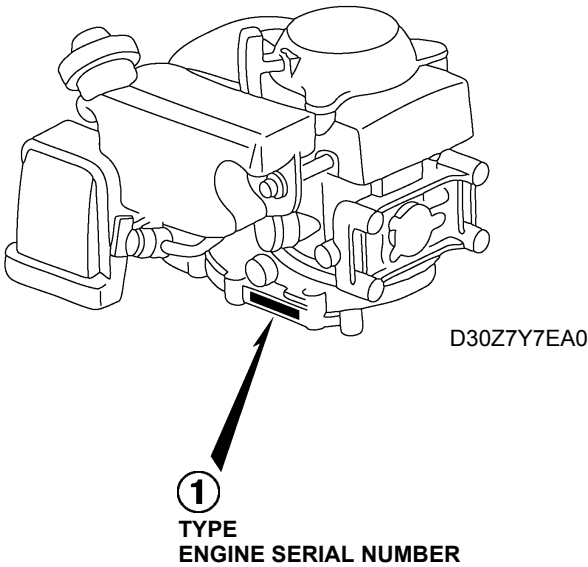
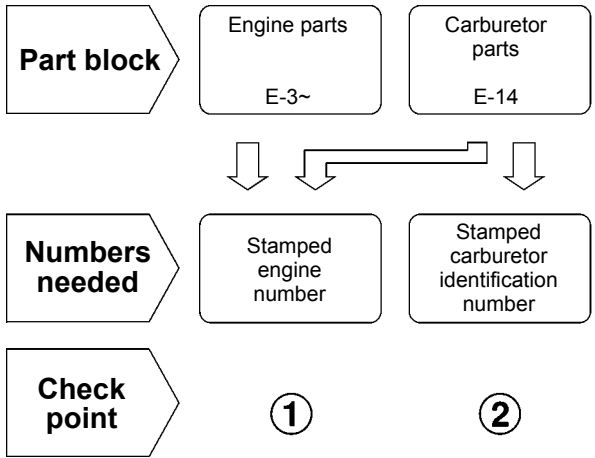

Models, parts catalogue codes and applicable serial numbers

- Models, parts catalogue codes and applicable serial Nos. given in this parts catalogue can be identified as follows.

Model	Type	Parts catalogue type	Applicable engine serial No.	Applicable carburetor identification No.
GXV57U	N7E1	N7E1	GJAJK-1000001~	BF31K A

* Of carburetor identification numbers, only the portions underlined in the example below are used for registration.

BF 31K A KC ナ
 (A) (B)

Fuel hose, general purpose hoses and vinyl hose

- The standard part fuel hose, general purpose hose and vinyl hose may be substituted by the coiled bulk part.
- When ordering the standard part fuel hose, general purpose hose and vinyl hose use the bulk part number written in the parts catalog in brackets () underneath the part name.
- When exchanging the hose, cut and use at the specified length as mentioned in the part name.
(For the method of cutting the bulk part, and method of filling out orders etc., please refer to the instructions issued with the bulk part.)

Bulk part number of fuel hose, general purpose hose and vinyl hose.

Example: 9 5 0 0 1 - 7 5 0 0 1 - 5 0 M

Bulk part number:
Refers to the bulk part.

Marking code (fuel hose and general purpose hose)

Change code (Vinyl hose)

Indicates number mark or change sequence, however, the code for the bulk part must be strictly 0 (zero).

Types of code:

- | | | | | | |
|-------------|--|----------------|--|--------------|---|
| • Fuel hose | 2: Red outside braid
(3 mm inside dia. only) | • General hose | 1: Ash gray
2: Ash gray
3: Black
5: Black | • Vinyl hose | 1: Clear
2: Black
3: Light red
6: Light red
7: Pale black |
| | 5: Black inside braid | | | | |
| | 3: Red (3 mm inside dia. only) | | | | |
| | 4: Ash gray with red stripe
(3 mm inside dia. only) | | | | |
| | 6: Black | | | | |

Lengths:

- 001: 1 m (standard)
003: 3 m
008: 8 m } Application or specification of some parts is not settled.

I.D code: (fuel hose and general purpose hose)

- | | | | | |
|------------|--------------------|--------------------|-----------------------------|-----------------------------|
| 30: 3.0 mm | 50: 5.0 mm | 70: 7.0 mm | 11: 11 mm | 12: 12 (outside dia. 17) mm |
| 35: 3.5 mm | 55: 5.3 mm, 5.5 mm | 75: 7.3 mm, 7.5 mm | 91: 12 (outside dia. 15) mm | 14: 14 mm |
| 45: 4.5 mm | 65: 6.5 mm | 80: 8.0 mm | 92: 12 (outside dia. 16) mm | 17: 17 mm |

ID./OD. code: (vinyl hose)

- | | | | | |
|-------------------------|--------------------------|---------------------------|---------------------------|---------------------------|
| 01: ID. 2.9, OD. 6.8 mm | 12: ID. 5.0, OD. 7.0 mm | 21: ID. 8.0, OD. 9.0 mm | 37: ID. 11.0, OD. 15.0 mm | 50: ID. 16.0, OD. 19.0 mm |
| 03: ID. 3.0, OD. 6.0 mm | 10: ID. 5.0, OD. 8.0 mm | 23: ID. 8.0, OD. 12.0 mm | 38: ID. 12.0, OD. 13.0 mm | 55: ID. 17.5, OD. 20.5 mm |
| 05: ID. 3.5, OD. 6.5 mm | 11: ID. 5.0, OD. 9.0 mm | 25: ID. 9.0, OD. 11.0 mm | 39: ID. 12.0, OD. 14.0 mm | 60: ID. 22.0, OD. 27.0 mm |
| 07: ID. 4.0, OD. 7.0 mm | 14: ID. 6.0, OD. 9.0 mm | 27: ID. 9.0, OD. 13.0 mm | 40: ID. 12.0, OD. 16.0 mm | |
| 08: ID. 4.5, OD. 6.5 mm | 17: ID. 7.0, OD. 9.0 mm | 33: ID. 10.0, OD. 14.0 mm | 43: ID. 13.0, OD. 15.0 mm | |
| 09: ID. 4.5, OD. 8.0 mm | 19: ID. 7.0, OD. 11.0 mm | 36: ID. 11.0, OD. 13.0 mm | 45: ID. 14.0, OD. 18.0 mm | |

Hose type:

- 1: Fuel hose
3: Vinyl hose
5: General hose

⊙ **CAUTION: It is DANGEROUS to confuse the fuel hose with the general purpose hose or vinyl hose.**

Never use a general purpose hose or vinyl hose in place of a fuel hose or vice versa. Always use the correct bulk part in the parts catalogue, according to the service manual or the instructions issued with the bulk part.

FLAT RATE SERVICE TIME

Flat rate service time (FRT) means the standard time required to service a product, which is listed in this manual to help the dealers control the actual working process and calculate the service charge by using it as a guide.

FRT setting system

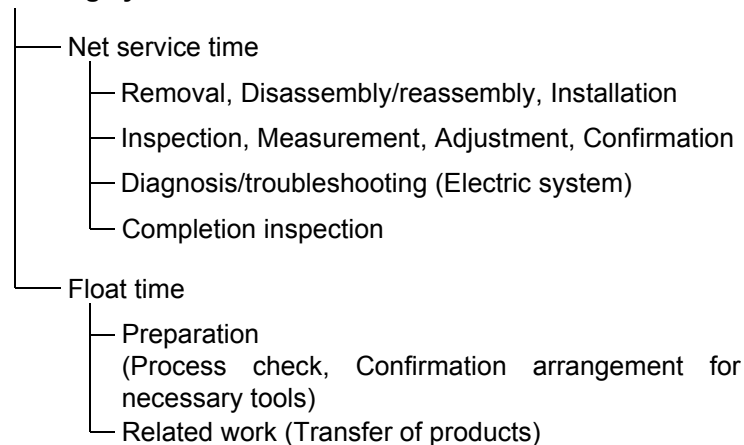

* Float time is set by multiplying the net service time by a given coefficient.

Editorial style

The service items shown in the text are listed with the exchange work time for the repair sales parts as the subject. Other representative service items not using repair parts (removal/installation, adjustment, inspection/measuring, and other work) are listed collectively in the list in the preface, classified according to the work.

FRT setting standard

- Decimal system (in unit of 0.1) is adopted to set FRT as it is convenient to calculate the wage.
Example: (0.1) → 6 minutes, (0.2) → 12 minutes
[Labor cost per hour] x [FRT] = [Wage]
- FRT is set with a hand tool.
- Service items and FRT can be subject to change depending on development of tools and service equipment and improvement in service procedure.

Work procedure

- As the work procedure is set with the work time according to the method in the separate Service Manual, refer to this Manual as required.
- Work methods permitting servicing in the shortest time still permitting assurance of safe work and product warranty are used for the setting of service items not listed in the Service Manual.
- Work basically is to be performed by one person, and when two or more people are required, setting is done as the total time for the number of people.
- The set value for the technological level of the workers uses a person with three years of experience in the repair of Honda products as the standard.
- Special tools and service equipment used to set FRT are those specified or recommended in Service Manual.

Service item whose FRT is not presented

- Accessories and service parts that are not listed to use in this manual.
 - Locations with little aging deterioration or breakage during normal use.
 - Service work that can be finished by one touch.
 - Service work that is seldom done (i.e. extremely small causes of trouble and service frequency).
 - Products and parts whose location for installation differs according to its status of use and application.
- * When FRT is not presented, please calculate wages based on appropriate actual work time.

Operation not included of FRT

- Oil and coolant water draining, Waiting time for warming up operation and etc..
- Additional operation that involves removal/installation of standard exterior equipment.
- Indirect time spent for service by visiting the customer, trade-in, and delivery.
- Indirect time required for ordering and delivery of parts.
- Cost for grease, adhesive agent, etc. used for service work.

**Explanation of FRT by using an example
(The example may differ from the actual presented items)**

Ref. No.	L.O.N.	(Relative ref. Number) Description	F.R.T.
①	1111L1	(1, 3, 4, 7) VALVE, INTAKE4.1	②
②		• NOTE: OHV type	③
③	1111L1A	• Includes: Engine removal and installation	④
		One head (intake all) add 1.4	⑤

- ① Reference No. of the illustration of part that shows location of the replacement work.
- ② FRT is an abbreviation of Flat Rate Time indicating the standard service time required for the replacement.
- ③ LON is an abbreviation of Labor Operation Number, and it is a classification of the service items by the work unit code.

The same operation code is used regardless of the models.

Standard operation is indicated with 6 digits code, and additional operation is indicated with 7 digits code.

- ④ Indicating the intake valve replacement and FRT4.1.
- ⑤ Indicating FRT1.4 that will be added when additional operation (whole intake side of one cylinder head) is done in association with intake valve replacement.

- ⑥ Indicating work condition or application condition of the service item.
- ⑦ Indicating work contents that are included in the service item.
- ⑧ Indicating a reference No. whose operation and time are the same as FRT4.1 for the intake valve.

(The application range is limited to the service items without an LON setting within a same block.)

**How to refer to the service item by using the sample
(intake valve replacement)**

Open to the page of the block where the intake valve's spare part illustration is shown.

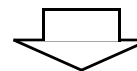

Look for the intake valve illustration, and refer to the service item and FRT that agree with the reference No.

Indication mark for the listing of service items that continues to the following page

Ref. No.	L.O.N.	(Relative ref. Number) Description	F.R.T.
2	1111L1	VALVE, INTAKE	4.1
	.	.	.
	.	.	.

+
Mark indicated at the last line.

Indication of the block with no setting of FRT

Ref. No.	L.O.N.	(Relative ref. Number) Description	F.R.T.
NO INFORMATION			

• LON code system

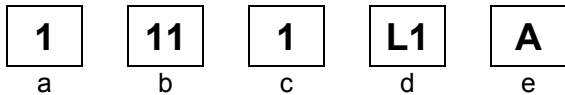

- a) Category code..... Engine
- b) Location/function code Engine upper
- c) Operation code..... Replace
- d) Operation sequence number (Unit code can be shown with alphabet)
..... Intake valve
(No regular rule of code)
- e) Additional code One head (intake all)
(No regular rule of code)

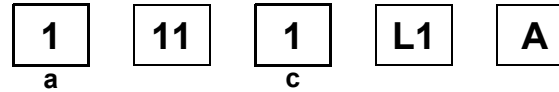

a) Category codes and classification

Code	Category
1	Engine
2	Power drive
3	Fuel & Exhaust
4	Frame & Body
5	Steering
6	Electrical
7	Axle & Brake
8	Control system
9	-
0	Attachments

c) Operation codes and classification

Code	Operation category
1	Replace, Removal/Installation, Change
2	Overhaul
3	Adjust, Rotation
4	(Paint-related work: Top-coat)
5	Test, Inspect/diagnose, Measurement
6	(Overhaul-related work: Rebore)
7	(Overhaul-related work: Reseal)
8	(Resurface)
9	(Paint-related work: Refinish)
0	Repair, Cleaning, Air bleeding

Major service items without using spare parts

(1) Removal/Installation, (2) Adjustment, (3) Inspection/
Measurement, (4) Overhaul, (5) Other work

E: Engine, T: Transmission, D: Drive system, B: Body and related
parts

(2) Adjustment

	LON	DESCRIPTION	FRT
E	1113A1	VALVE CLEARANCE-ADJUSTMENT NOTE: For 1 product	0.3
	1163A0	CONTROL, THROTTLE/GOVERNOR- ADJUSTMENT	0.2
	3113A2	CARBURETOR IDLE-ADJUSTMENT	0.2

(3) Inspection, Measurement, Cleaning

	LON	DESCRIPTION	FRT
E	1105A0	ENGINE OIL-INSPECTION	0.1
	3120A0	AIR CLEANER-CLEANING INCLUDES: Air cleaner-inspection	0.1
	3130A0	SPARK ARRESTER-CLEANING	0.2
	6140A0	SPARK PLUG-ADJUSTMENT/CLEANING NOTE: For 1 product	0.1

(4) Overhaul

Work condition: The required Measurements, inspections, adjustments, and cleaning/washing of each part are performed, including the main body removal/installation work and the replacement of defective parts.

	LON	DESCRIPTION	FRT
E	3112A0	CARBURETOR-OVERHAUL INCLUDES: All necessary adjustment	0.4

ENGINE GROUP

B13

E-3

CYLINDER BARREL

C 1

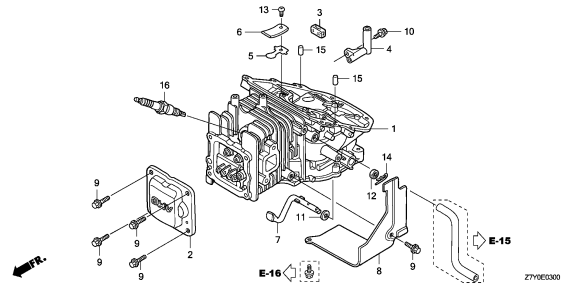

Z7Y0E0300

E-3-10

OIL CASE

C 2

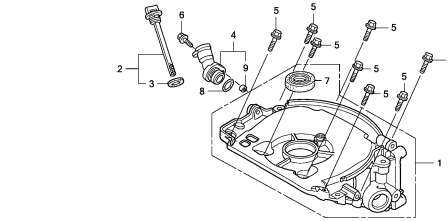

Z7Y0E0310

E-6

CRANKCASE SIDE COVER

C 3

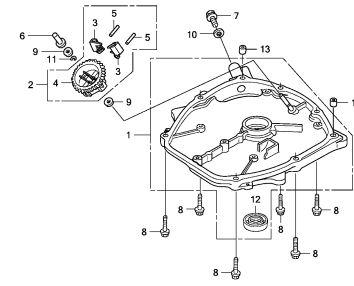

Z7Y0E0600

E-7

CRANKSHAFT

C 4

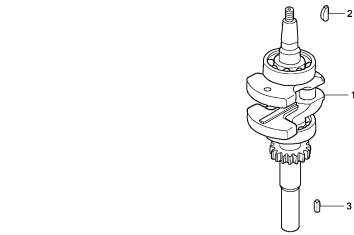

Z7Y0E0700

E-8

PISTON/CONNECTING ROD

C 5

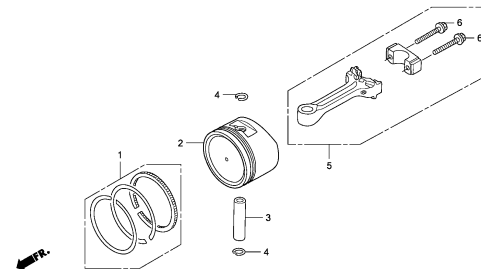

Z7Y0E0800

E-9

CAMSHAFT

C 6

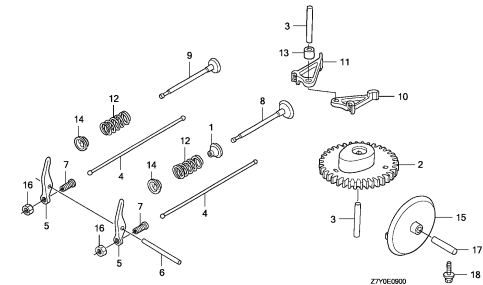

Z7Y0E0900

E-11

RECOIL STARTER

C 8

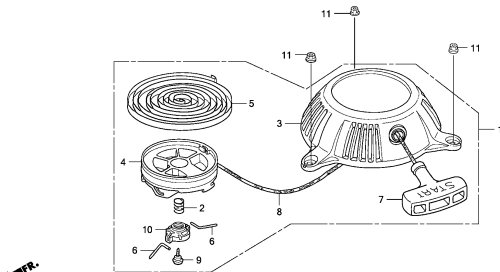

Z7Y0E1100

E-12

FAN COVER

C 9

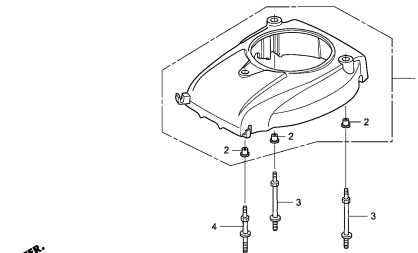

Z7Y0E1200

E-14

CARBURETOR

C10

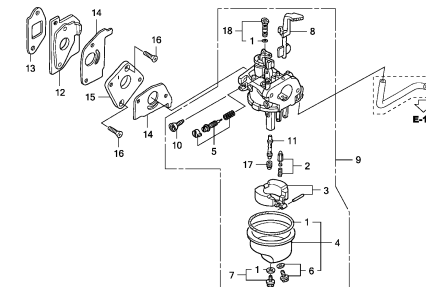

Z7Y0E1400

2

ENGINE GROUP

B14

E-15

AIR CLEANER

C11

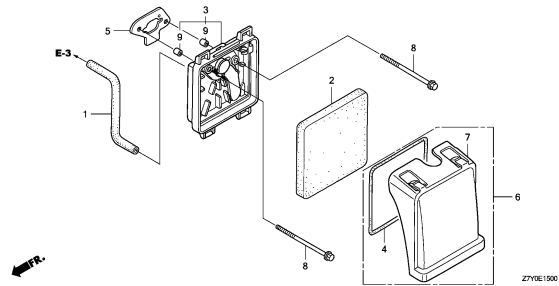

E-16

MUFFLER

C12

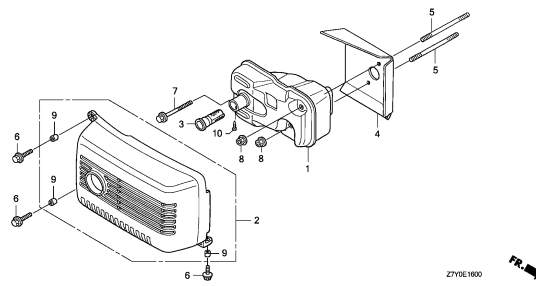

E-17

FUEL TANK

C13

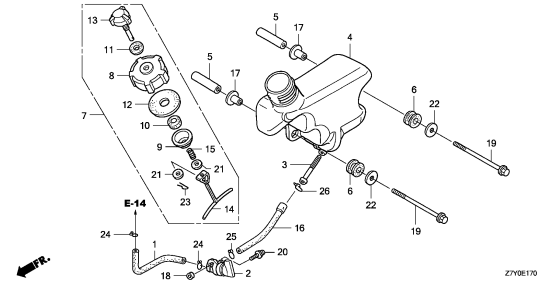

E-19

FLYWHEEL/IGNITION COIL

C14

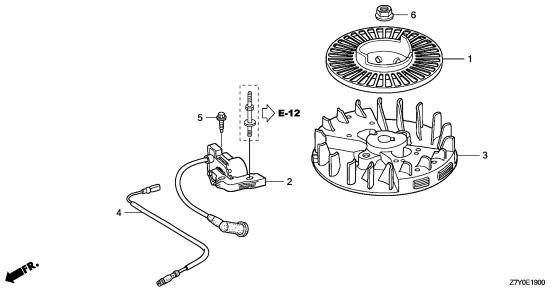

E-22

CONTROL

C15

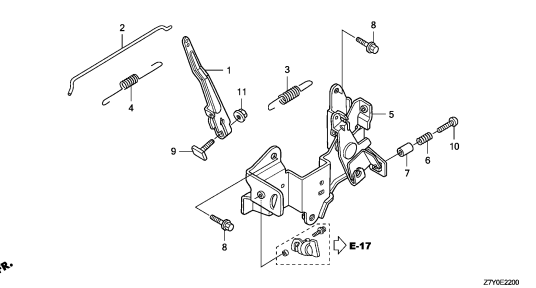

E-28

LABEL/TOOL

C16

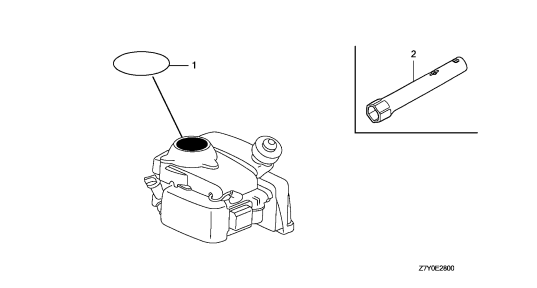

2

E-3

CYLINDER BARREL

C 1

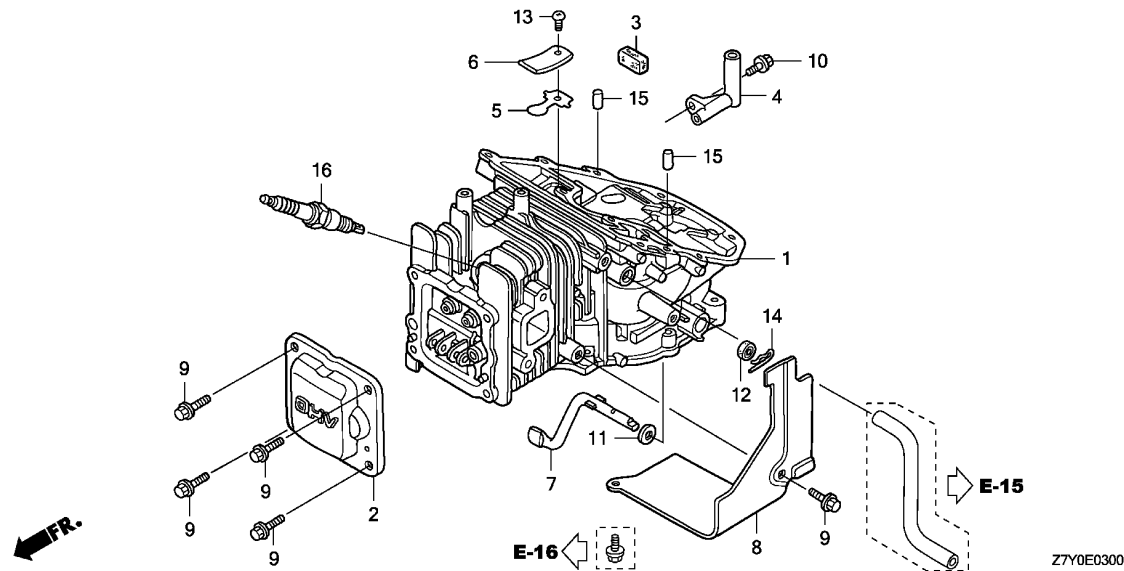

Ref. No.	L.O.N.	(Relative ref. Number) Description	F.R.T.
1	1101A0	BARREL, CYLINDER	1.7
2	1111D5	COVER, CYLINDER HEAD AND/OR PACKING, HEAD COVER	0.2
3	1111E5	FILTER, BREATHER	0.7
4	1111G1	PIPE, BREATHER	0.6
5		(6)	
	1171A8	VALVE, OIL OUTLET	0.7
7	1161B4	SHAFT, GOVERNOR ARM	1.2
8	4141E3	SHROUD, ENGINE	0.2
12	1101C4	OIL SEAL, GOVERNOR ARM SHAFT ..	1.2
16	6141C1	PLUG, SPARK	0.1

Ref. No.	Part No.	Description	Reqd. QTY		Serial No.	Parts catalogue code
			GXV	57U		
1	12100-ZM7-417	BARREL COMP., CYLINDER	1			
2	12311-ZM7-010	COVER, HEAD	1			
3	12367-ZE6-010	FILTER, BREATHER	1			
4	15171-ZN4-000	PIPE, BREATHER	1			
5	15571-ZM7-003	VALVE, OIL OUTLET	1			
6	15572-ZM7-000	PLATE, STOPPER	1			
7	16541-ZM7-000	SHAFT, GOVERNOR ARM	1			
8	19631-ZM7-000	SHROUD	1			
9	90003-892-000	BOLT, FLANGE, 5X12	5			
10	90008-ZM7-000	BOLT, 4X10	1			
11	90443-ZC3-000	WASHER, 5.2X9	1			
12	91231-ZC3-003	OIL SEAL, 5X11X5	1			
13	93500-03005-0A	SCREW, PAN, 3X5	1			
14	94251-06000	PIN, LOCK, 6MM	1			
15	96220-60150	ROLLER, 6X15	2			
16	98056-54757	PLUG, SPARK (U14FSR-UB)	(1)			
	98056-54777	PLUG, SPARK (CR4HSB)	(1)			
	98056-55757	PLUG, SPARK (U16FSR-UB)	1			
	98056-55777	PLUG, SPARK (CR5HSB)	1			

2

E-3-10

OIL CASE

C 2

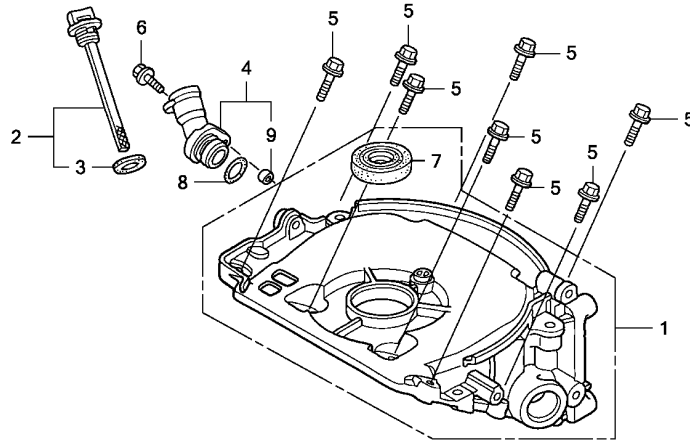

←FR.

Ref. No.	L.O.N.	(Relative ref. Number) Description	F.R.T.
1	1101F1	COVER, CRANKCASE	0.8
4		(8,9)	
	1101B9	EXTENSION, OIL FILLER AND/OR PACKING, OIL FILLER EXTENSION	0.1
7	1101E6	OIL SEAL, CRANKSHAFT :UPPER ..	0.8

Ref. No.	Part No.	Description	Reqd. QTY		Serial No.	Parts catalogue code
			GXV	57U		
1	11300-ZN4-405	CASE ASSY., OIL	1			
2	15600-ZN4-003	CAP ASSY., OIL FILLER	1			
3	15625-ZE1-003	PACKING, OIL FILLER CAP	1			
4	15631-ZN4-000	EXTENSION, OIL FILLER	1			
5	90006-ZM7-000	BOLT, FLANGE, 5X23	8			
6	90012-896-750	BOLT, FLANGE, 5X14	1			
7	91202-HC5-003	OIL SEAL, 17X27X5 (ARAI)	1			
8	91331-PC9-003	O-RING, 21.2X2.4 (ARAI)	1			
9	91502-ZM3-000	COLLAR, TOP COVER	1			

2

E-6

CRANKCASE SIDE COVER

C 3

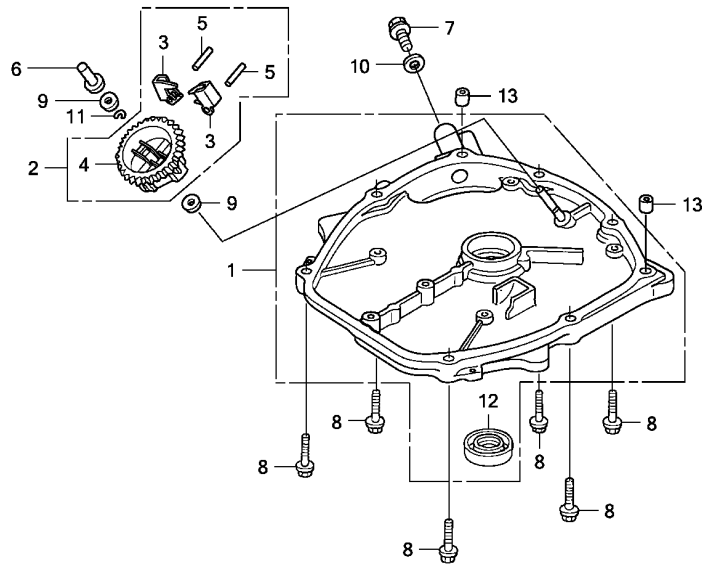

Z7Y0E0600

Ref. No.	L.O.N.	(Relative ref. Number) Description	F.R.T.
1	1101B3	COVER, CRANKCASE SIDE	0.5
2	1161C4	GOVERNOR ASSEMBLY	0.5
4		(3)	
	1161A7	HOLDER, GOVERNOR WEIGHT	0.5
6	1161B6	SLIDER, GOVERNOR	0.4
12	1101E7	OIL SEAL, CRANKSHAFT :LOWER ..	0.4

Ref. No.	Part No.	Description	Reqd. QTY		Serial No.	Parts catalogue code
			GXV	57U		
1	11340-Z7Y-000	COVER COMP., CRANKCASE SIDE .	1			
2	16510-ZM7-000	GOVERNOR ASSY.	1			
3	16511-ZM7-000	WEIGHT, GOVERNOR	2			
4	16512-ZM7-000	HOLDER, GOVERNOR WEIGHT	1			
5	16513-ZE1-000	PIN, GOVERNOR WEIGHT	2			
6	16531-ZM7-000	SLIDER, GOVERNOR	1			
7	90002-ZN4-A50	BOLT, PLUG DRAIN, 12MM	1			
8	90006-ZM7-000	BOLT, FLANGE, 5X23	6			
9	90441-ZM7-000	WASHER, 4.2X13	2			
10	90601-VE5-000	WASHER, DRAIN PLUG, 12MM	1			
11	90602-ZM7-000	CLIP, GOVERNOR HOLDER	1			
12	91202-GB4-692	OIL SEAL, 18.9X28X5 (ARAI) ...	1			
13	94301-06100	DOWEL PIN, 6X10	2			

2

E-7

CRANKSHAFT

C 4

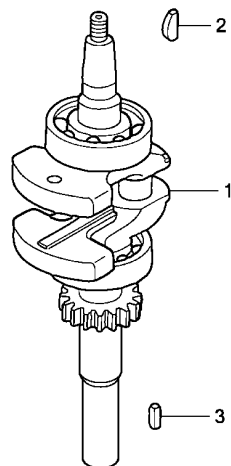

Z7Y0E0700

Ref. No.	L.O.N.	(Relative ref. Number) Description	F.R.T.
1	1101F0	CRANKSHAFT	1.2

2

FR.

Ref. No.	Part No.	Description	Reqd. QTY	Serial No.	Parts catalogue code
			GXV 57U		
1	13310-Z7Y-000	CRANKSHAFT COMP.	1		
2	13331-ZM7-000	KEY, SPECIAL	1		
3	90741-959-000	KEY, 5MM	(1)		

E-8

PISTON/CONNECTING ROD

C 5

FR.

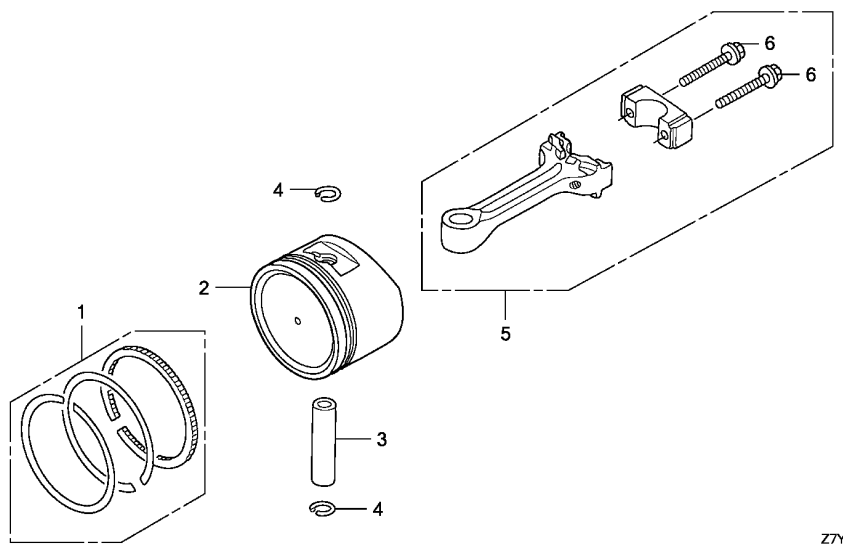

Ref. No.	L.O.N.	(Relative ref. Number) Description	F.R.T.
2		(1,3,5)	
1111R1		PISTON AND/OR RING SET AND/OR BEARING AND/OR RODINCLUDES: Inspection/ Measurement/Cleaning	1.3

Ref. No.	Part No.	Description	Reqd. QTY		Serial No.	Parts catalogue code
			GXV	57U		
1	13010-ZM7-000	RING SET, PISTON (STD.)	1			
2	13101-ZW6-010	PISTON	1			
3	13111-122-000	PIN, PISTON, 10X33	1			
4	13115-147-000	CLIP, PISTON PIN, 10MM	2			
5	13200-ZN4-000	ROD ASSY., CONNECTING	1			
6	90001-ZM7-000	BOLT, CONNECTING ROD	2			

2

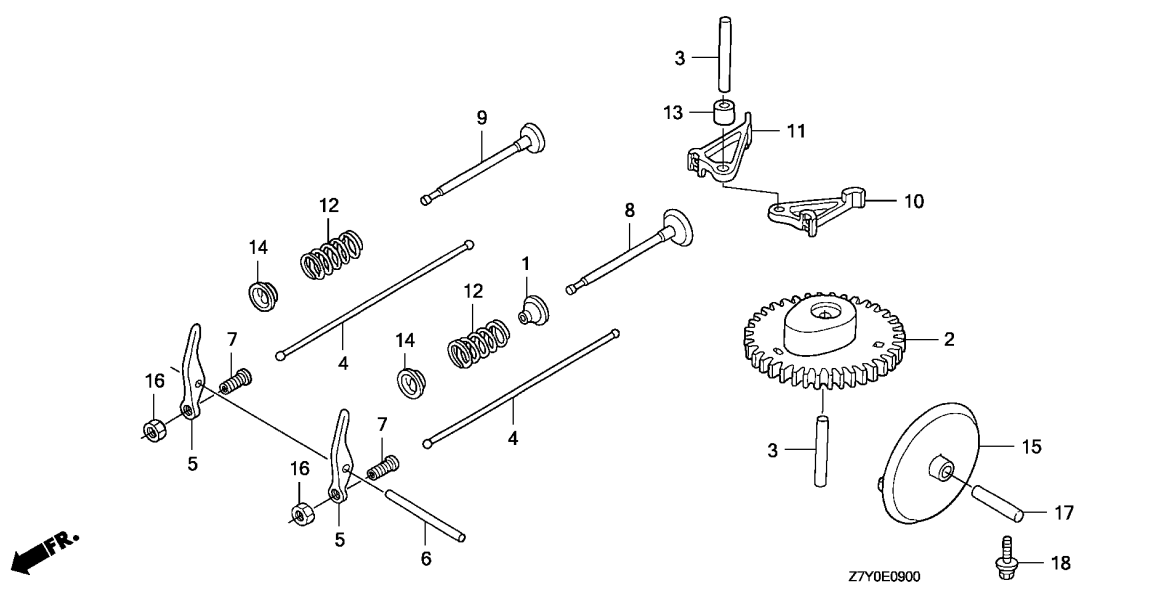

Ref. No.	L.O.N.	(Relative ref. Number) Description	F.R.T.
1	1111K2	SEAL, INTAKE VALVE STEMINCLUDES: Valve clearance adjustment	1.3
2	1111C2	CAMSHAFTINCLUDES: Engine removal and installation .INCLUDES: Valve clearance adjustment	0.5
4	1111L6	ROD, PUSH :INTAKEINCLUDES: Valve clearance adjustment	0.5
	1111L6A	.Replace exhaust push rod add	0.1
	1111L7	ROD, PUSH :EXHAUSTINCLUDES: Valve clearance adjustment	0.5
	1111L7A	.Replace intake push rod add	0.1
5	1111A2	ARM, ROCKER :INTAKEINCLUDES: Valve clearance adjustment	0.4
	1111A2A	.Replace exhaust rocker arm add	0.1
	1111A1	ARM, ROCKER :EXHAUSTINCLUDES: Valve clearance adjustment	0.4
	1111A1A	.Replace intake rocker arm add	0.1

Ref. No.	Part No.	Description	Reqd. QTY		Serial No.	Parts catalogue code
			GXV	57U		
1	12209-ZM7-003	SEAL, VALVE STEM	1			
2	14100-Z0G-000	CAMSHAFT ASSY.	1			
3	14126-Z0G-003	ROLLER (5X29.8)	2			
4	14410-ZM7-000	ROD, PUSH	2			
5	14431-ZM7-000	ARM, VALVE ROCKER	2			
6	14435-ZM7-003	ROLLER (4X37.8)	1			
7	14451-ZM7-000	PIVOT, ROCKER ARM	2			
8	14711-ZM7-000	VALVE, IN.	1			
9	14721-ZM7-000	VALVE, EX.	1			
10	14731-ZM7-013	LIFTER, VALVE	1			
11	14732-Z0G-003	LIFTER, EX. VALVE	1			
12	14751-ZM7-000	SPRING, VALVE	2			
13	14754-ZM7-000	COLLAR, LIFTER	1			
14	14771-ZM3-010	RETAINER, VALVE SPRING	2			
15	15361-Z0G-000	SLINGER, OIL	1			
16	90206-KM3-000	NUT, TAPPET ADJUSTING	2			
17	91151-VB5-800	ROLLER, 6X25	1			
18	93404-05016-08	BOLT-WASHER, 5X16	1			

FR.

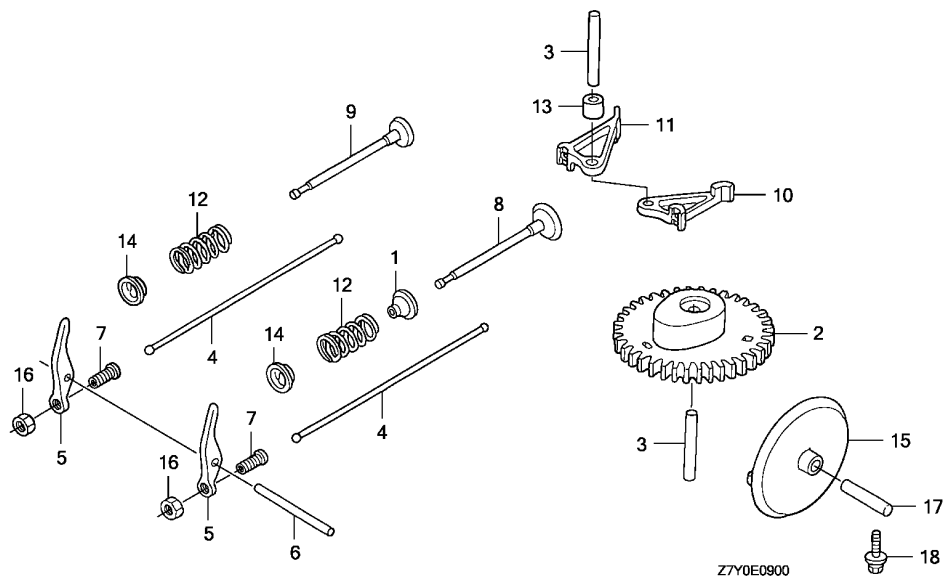

Ref. No.	L.O.N.	(Relative ref. Number) Description	F.R.T.
8	1111L1	VALVE, INTAKE	1.4
	1111L1E	.Replace intake and exhaust all add	0.1
9	1111L0	VALVE, EXHAUST	1.4
	1111L0E	.Replace intake and exhaust all add	0.1
10	1111L9	LIFTER, VALVE :INTAKE	0.5
11	1111M0	LIFTER, VALVE :EXHAUST	0.5
15	1101K6	GEAR, OIL SLINGER DRIVEN	0.5

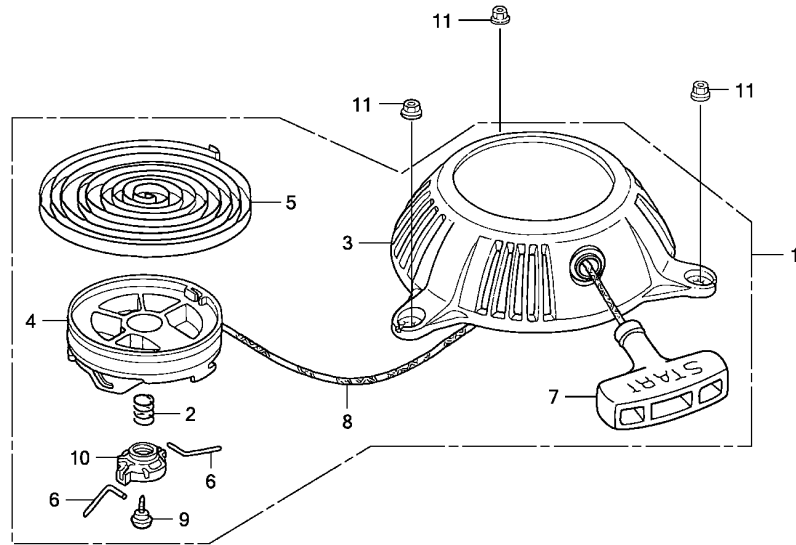

Z7Y0E1100

Ref. No.	L.O.N.	(Relative ref. Number) Description	F.R.T.
1	1121B9	STARTER, RECOIL	0.1
4	1121B1	REEL, RECOIL STARTER	0.3
5	1121B7	SPRING, RECOIL STARTER RETURN	0.3
7	1121A3	GRIP, RECOIL STARTER	0.1
8	1121B3	ROPE, RECOIL STARTER	0.3

Ref. No.	Part No.	Description	Reqd. QTY		Serial No.	Parts catalogue code
			GXV	57U		
1	28400-ZM7-V31	STARTER ASSY., RECOIL	1			
2	28404-968-004	SPRING, FRICTION	1			
3	28410-ZM7-V31	CASE COMP., STARTER	1			
4	28421-ZM7-003	REEL, RECOIL STARTER	1			
5	28442-ZL8-003	SPRING, RECOIL STARTER	1			
6	28459-ZM7-003	ARM, SWING	2			
7	28461-ZH8-003	GRIP, STARTER	1			
8	28462-ZOG-003	ROPE, RECOIL STARTER	1			
9	90012-ZM3-003	SCREW, SETTING	1			
10	91504-ZM7-003	COLLAR	1			
11	94050-05000	NUT, FLANGE, 5MM	3			

2

FR.

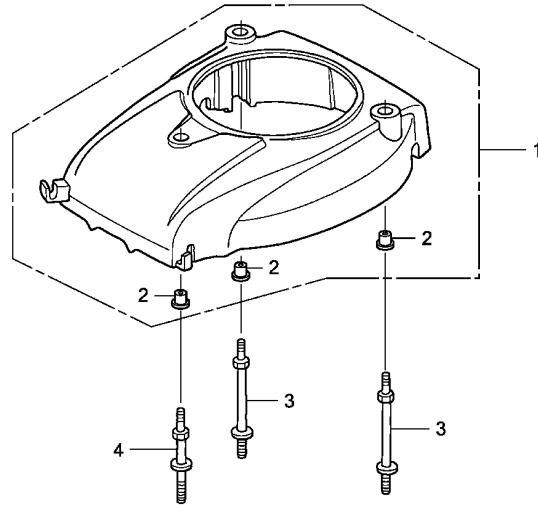

Z7Y0E1200

Ref. No.	L.O.N.	(Relative ref. Number) Description	F.R.T.
1	1141G8	COVER, ENGINE COOLING FAN	0.2

Ref. No.	Part No.	Description	Reqd. QTY		Serial No.	Parts catalogue code
			GXV	57U		
1	19610-ZM7-000ZD	COVER COMP., FAN *NH1*.....BLACK	1			
2	19619-ZM7-300	COLLAR, FAN COVER	3			
3	90042-ZM7-000	BOLT, STUD (A)	2			
4	90043-ZM7-000	BOLT, STUD (B)	1			



E-14

CARBURETOR

C10

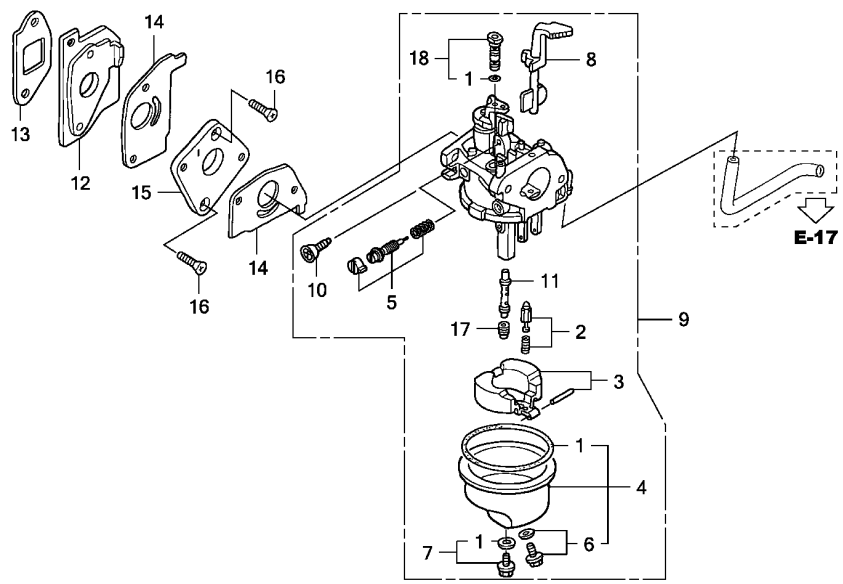

Ref. No.	L.O.N.	(Relative ref. Number) Description	F.R.T.
2		(3)	
3111E1		VALVE SET, FLOAT AND/OR FLOAT SET	0.3
5	3111D7	SCREW SET, PILOT	0.2
8	8101C5	CHOKE SET, CARBURETOR	0.2
9	3111F3	CARBURETOR	0.2
12		(13)	
3111C0		INSULATOR, CARBURETOR AND/OR PACKING, INSULATOR	0.2
14	3111C8	PACKING, CARBURETOR	0.2
15	3111H5	PLATE, CARBURETOR JOINT	0.2
17	3111C3	JET, MAIN	0.3

Ref. No.	Part No.	Description	Reqd. QTY	Serial No.	Parts catalogue code
			GXV 57U		
1	16010-ZG2-D10	GASKET SET	1		
2	16011-ZE0-005	VALVE SET, FLOAT	1		
3	16013-ZG0-811	FLOAT SET	1		
4	16015-ZG0-811	CHAMBER SET, FLOAT	1		
5	16016-ZH7-W01	SCREW SET, PILOT	1		
6	16024-ZE1-811	SCREW SET, DRAIN	1		
7	16028-ZG0-811	SCREW SET	1		
8	16044-ZM7-003	CHOKE SET	1		
9	16100-Z7Y-003	CARBURETOR ASSY. (BF31K A) ..	1		
10	16124-ZE0-005	SCREW, THROTTLE STOP	1		
11	16166-ZN4-801	NOZZLE, MAIN	1		
12	16211-ZN4-000	INSULATOR, CARBURETOR	1		
13	16212-ZM7-000	PACKING, INSULATOR	1		
14	16221-ZG0-801	PACKING, CARBURETOR	2		
15	16225-ZN4-000	PLATE, CARBURETOR JOINT	1		
16	93600-05020-0A	SCREW, FLAT, 5X20	2		
17	99101-ZG0-0480	JET, MAIN, #48	(1)		
	99101-ZG0-0500	JET, MAIN, #50	(1)		
	99101-ZG0-0520	JET, MAIN, #52	1		
18	99204-ZE2-0350	JET SET, PILOT, #35	1		

2

E-15

AIR CLEANER

C11

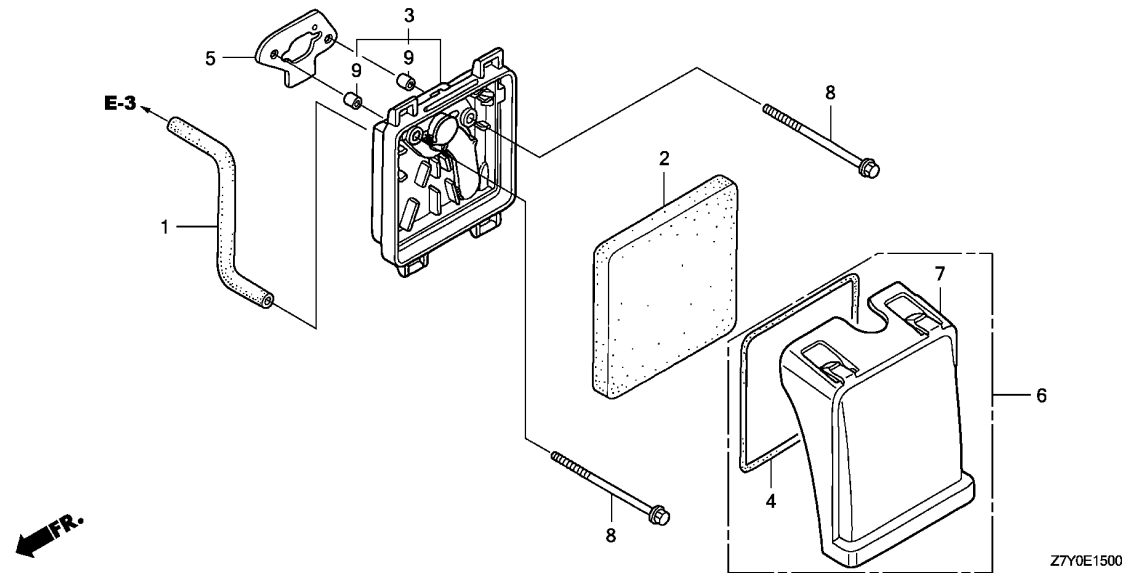

Ref. No.	L.O.N.	(Relative ref. Number) Description	F.R.T.
1	1111K5	TUBE, BREATHER	0.1
2	3121B8	ELEMENT, AIR CLEANER	0.1
.INCLUDES: Air cleaner-inspection			
3	3121A5	CASE, AIR CLEANER	0.1
4	3121E9	SEAL, AIR CLEANER COVER	0.1
5	3121D9	PACKING, AIR CLEANER	0.1

Ref. No.	Part No.	Description	Reqd. QTY		Serial No.	Parts catalogue code
			GXV	57U		
1	15721-ZN4-000	TUBE, BREATHER	1			
2	17211-ZM7-000	ELEMENT, AIR CLEANER	1			
3	17220-ZM7-000	CASE COMP., AIR CLEANER	1			
4	17227-ZM7-000	SEAL, AIR CLEANER	1			
5	17228-ZM7-000	PACKING, AIR CLEANER	1			
6	17230-ZM7-000	COVER COMP., AIR CLEANER	1			
7	17231-ZM7-000	COVER, AIR CLEANER	1			
8	90004-ZN4-000	BOLT, FLANGE, 5X65	2			
9	91503-ZM7-000	COLLAR, AIR CLEANER	2			

2

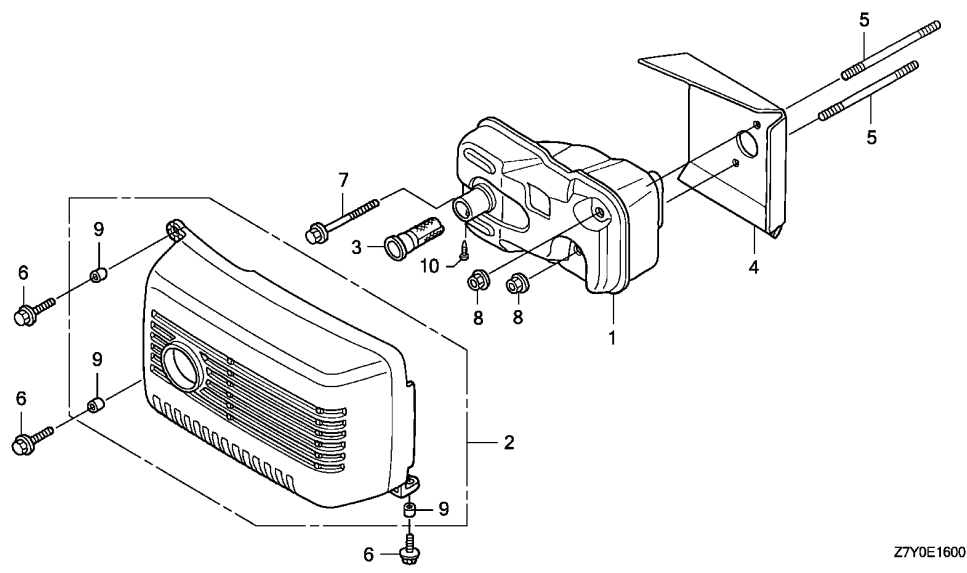

Ref. No.	L.O.N.	(Relative ref. Number) Description	F.R.T.
1	3131C5	MUFFLER, EXHAUST	0.2
2	3131D6	PROTECTOR, EXHAUST MUFFLER ...	0.1
3	3131A1	ARRESTER, SPARK	0.2
		.INCLUDES: Spark arrester check	
4	3131B6	GUIDE, AIR EXHAUST	0.2

Z7Y0E1600



Ref. No.	Part No.	Description	Reqd. QTY		Serial No.	Parts catalogue code
			GXV	57U		
1	18310-ZM7-003	MUFFLER COMP.	1			
	18310-ZM7-801	(1)			
2	18320-ZM7-000	PROTECTOR COMP., MUFFLER	1			
3	18350-ZM7-801	ARRESTER COMP., SPARK	(1)			
4	18515-ZM7-000	GUIDE, AIR	1			
5	90002-ZM7-000	BOLT, STUD, 5X55	2			
6	90012-892-000	BOLT, FLANGE, 5X16	3			
7	90103-P4V-010	BOLT, FLANGE, 5X35	1			
8	90136-SM4-901	NUT, SELF-LOCK, 5MM	2			
9	91502-ZM3-000	COLLAR, TOP COVER	3			
10	93903-24110	SCREW, TAPPING, 4X8	(1)			

E-17

FUEL TANK

C13

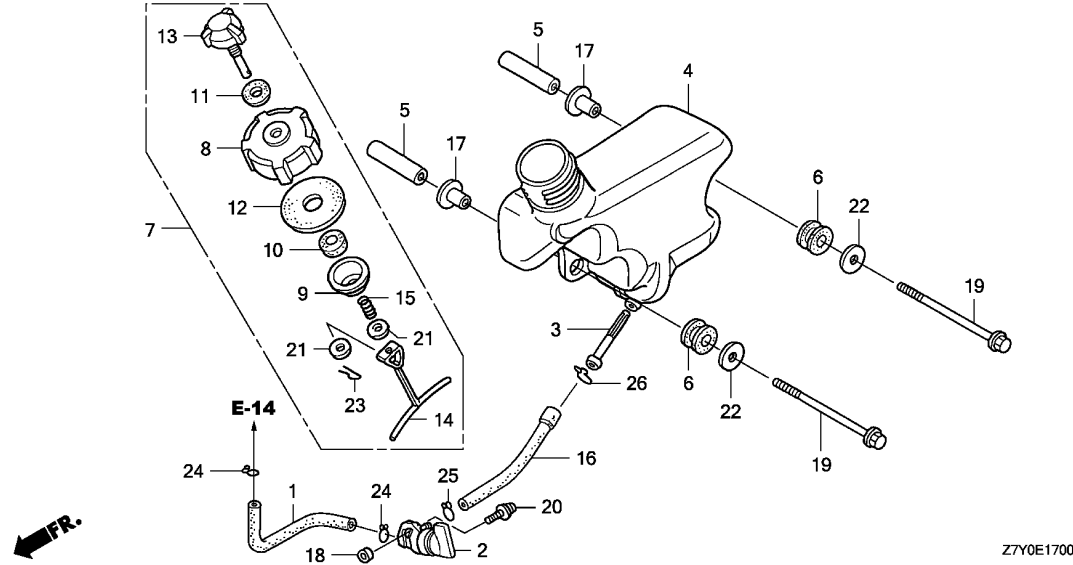

Ref. No.	L.O.N.	(Relative ref. Number) Description	F.R.T.
1	3101F7	TUBE B, FUEL	0.1
2	3101A3	COCK, FUEL	0.1
3	3101H8	STRAINER, FUEL	0.1
4	3101H7	TANK, FUEL	0.1
6	3101M3	RUBBER A, TANK MOUNTING	0.1
16	3101F1	TUBE, FUEL TANK	0.1

.NOTE: Same time for two units

Ref. No.	Part No.	Description	Reqd. QTY	Serial No.	Parts catalogue code
			GXV 57U		
1	16861-ZN4-800	TUBE B, FUEL	1		
2	16950-ZM0-003	COCK ASSY., FUEL	1		
3	16952-ZE6-000	STRAINER, FUEL	1		
4	17511-Z4D-000	TANK, FUEL	1		
5	17517-ZN4-000	COLLAR, TANK SETTING	2		
6	17532-ZM7-000	RUBBER A, TANK MOUNTING	2		
7	17620-ZV0-020	CAP ASSY., FUEL TANK	1		
8	17621-ZV0-020	BODY, FUEL CAP	1		
9	17622-ZV0-000	INNER, FUEL CAP	1		
10	17623-ZV0-000	SPONGE, FUEL CAP BREATHER	1		
11	17624-ZV0-000	PACKING, VALVE	1		
12	17625-ZV0-000	PACKING, FUEL CAP	1		
13	17626-ZV0-010	VALVE COMP., BREATHER	1		
14	17628-ZV0-000	LINK, FUEL CAP	1		
15	17629-ZV0-000	SPRING, FUEL CAP	1		
16	17701-ZN4-800	TUBE, FUEL TANK	1		
17	19052-MB4-880	COLLAR, CANISTER MOUNTING	2		
18	33609-GK4-620	COLLAR, FR. WINKER	1		
19	90015-ZG0-801	BOLT, FLANGE, 6X65	2		
20	93891-05010-08	SCREW-WASHER, 5X10	1		
21	94101-04200	WASHER, PLAIN, 4MM	2		
22	94103-06800	WASHER, PLAIN, 6MM	2		
23	94251-04000	PIN, LOCK, 4MM	1		
24	95002-02080	CLIP, TUBE (B8)	2		
25	95002-02100	CLIP, TUBE (B10)	1		
26	95002-02130	CLIP, TUBE (B12.5)	1		

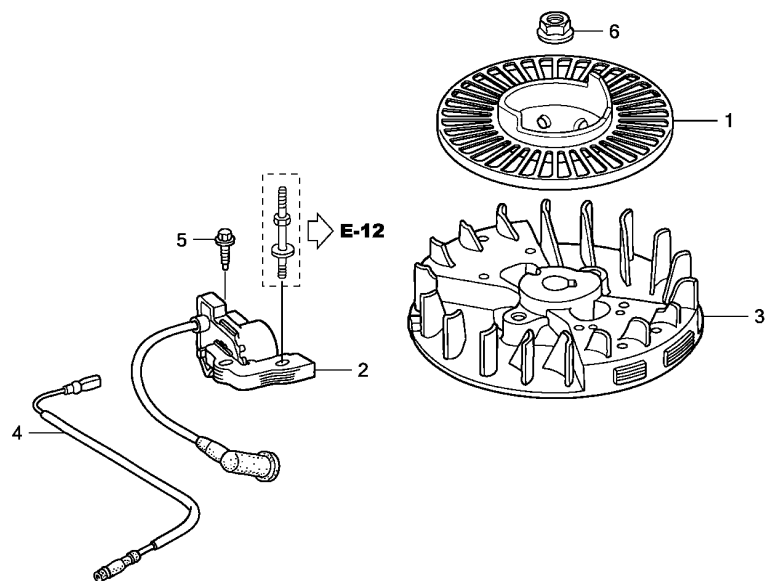

Ref. No.	L.O.N.	(Relative ref. Number) Description	F.R.T.
2	6141A5	COIL, IGNITION(ONE)	0.2
3	2161B5	FLYWHEEL	0.3
4	6111B3	CORD, STOP SWITCH	0.1

Ref. No.	Part No.	Description	Reqd. QTY		Serial No.	Parts catalogue code
			GXV	57U		
1	28450-Z7Y-003	PULLEY COMP., STARTER	1			
2	30500-ZM7-004	COIL ASSY., IGNITION	1			
3	31110-ZM7-004	FLYWHEEL COMP.	1			
4	32195-ZN4-000	CORD, STOP SWITCH	1			
5	90004-ZC3-000	BOLT, FLANGE, 5X20	1			
6	94050-10000	NUT, FLANGE, 10MM	1			

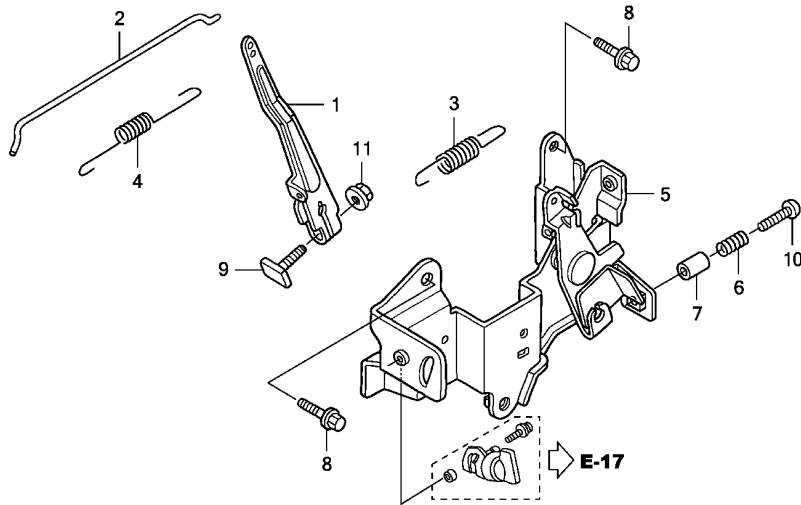

FR.

Z7Y0E2200

Ref. No.	L.O.N.	(Relative ref. Number) Description	F.R.T.
1	1161A0	ARM, GOVERNOR	0.2
2	1161B1	ROD, GOVERNOR	0.2
3	1161C5	SPRING, GOVERNOR	0.1
4	1161C2	SPRING, THROTTLE RETURN	0.2
5	1161A2	BASE, CONTROL	0.2

Ref. No.	Part No.	Description	Reqd. QTY		Serial No.	Parts catalogue code
			GXV	57U		
1	16551-ZN4-000	ARM, GOVERNOR	1			
2	16555-ZN4-000	ROD, GOVERNOR	1			
3	16561-ZN4-000	SPRING, GOVERNOR	1			
4	16562-ZN4-800	SPRING, THROTTLE RETURN	1			
5	16580-Z7Y-000	BASE COMP., CONTROL	1			
6	16584-883-300	SPRING, CONTROL ADJUSTING ...	1			
7	16599-ZG1-M10	COLLAR, STOPPER	1			
8	90003-892-000	BOLT, FLANGE, 5X12	2			
9	90015-ZE5-010	BOLT, GOVERNOR ARM	1			
10	90016-ZE7-W00	SCREW, RECESSED, 5X28	1			
11	94050-06000	NUT, FLANGE, 6MM	1			

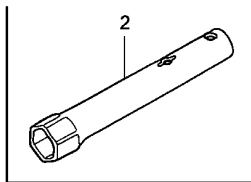
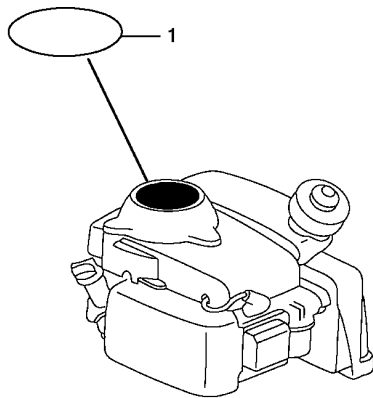

Z7Y0E2800

Ref. No.	L.O.N.	(Relative ref. Number)	Description	F.R.T.
----------	--------	------------------------	-------------	--------

NO INFORMATION

Ref. No.	Part No.	Description	Reqd. QTY		Serial No.	Parts catalogue code
			GXV	57U		
1	87521-Z7Y-000	EMBLEM		1		
2	89216-130-690	WRENCH, SPARK PLUG		(1)		

PART NO. INDEX

D 1

Part Number	Address	Page	Ref.	Part Number	Address	Page	Ref.	Part Number	Address	Page	Ref.	Part Number	Address	Page	Ref.
11000				16100-Z7Y-003	C10	24	9	19631-ZM7-000	C1	15	8	90136-SM4-901	C12	26	8
11300-ZN4-405	C2	16	1	16124-ZE0-005	C10	24	10	28000				90206-KM3-000	C6	20	16
11340-Z7Y-000	C3	17	1	16166-ZN4-801	C10	24	11					90441-ZM7-000	C3	17	9
				16211-ZN4-000	C10	24	12					90443-ZC3-000	C1	15	11
12000				16212-ZM7-000	C10	24	13	28400-ZM7-V31	C8	22	1	90601-VE5-000	C3	17	10
12100-ZM7-417	C1	15	1	16221-ZG0-801	C10	24	14	28404-968-004	C8	22	2	90602-ZM7-000	C3	17	11
12209-ZM7-003	C6	20	1	16225-ZN4-000	C10	24	15	28410-ZM7-V31	C8	22	3	90741-959-000	C4	18	3
12311-ZM7-010	C1	15	2	16510-ZM7-000	C3	17	2	28421-ZM7-003	C8	22	4				
12367-ZE6-010	C1	15	3	16511-ZM7-000	C3	17	3	28442-ZL8-003	C8	22	5	91000			
				16512-ZM7-000	C3	17	4	28450-Z7Y-003	C14	28	1				
13000				16513-ZE1-000	C3	17	5	28459-ZM7-003	C8	22	6	91151-VB5-800	C6	20	17
13010-ZM7-000	C5	19	1	16531-ZM7-000	C3	17	6	28461-ZH8-003	C8	22	7	91202-GB4-692	C3	17	12
13101-ZW6-010	C5	19	2	16541-ZM7-000	C1	15	7	28462-Z0G-003	C8	22	8	91202-HC5-003	C2	16	7
13111-122-000	C5	19	3	16551-ZN4-000	C15	29	1					91231-ZC3-003	C1	15	12
13115-147-000	C5	19	4	16555-ZN4-000	C15	29	2	30000				91331-PC9-003	C2	16	8
13200-ZN4-000	C5	19	5	16561-ZN4-000	C15	29	3	30500-ZM7-004	C14	28	2	91502-ZM3-000	C2	16	9
13310-Z7Y-000	C4	18	1	16562-ZN4-800	C15	29	4						C12	26	9
13331-ZM7-000	C4	18	2	16580-Z7Y-000	C15	29	5	31000				91503-ZM7-000	C11	25	9
				16584-883-300	C15	29	6					91504-ZM7-003	C8	22	10
				16599-ZG1-M10	C15	29	7	31110-ZM7-004	C14	28	3				
				16861-ZN4-800	C13	27	1					93000			
				16950-ZM0-003	C13	27	2	32000				93404-05016-08	C6	20	18
				16952-ZE6-000	C13	27	3	32195-ZN4-000	C14	28	4	93500-03005-0A	C1	15	13
14000												93600-05020-0A	C10	24	16
14100-Z0G-000	C6	20	2	17000				33000				93891-05010-08	C13	27	20
14126-Z0G-003	C6	20	3									93903-24110	C12	26	10
14410-ZM7-000	C6	20	4	17211-ZM7-000	C11	25	2	33609-GK4-620	C13	27	18				
14431-ZM7-000	C6	20	5	17220-ZM7-000	C11	25	3					94000			
14435-ZM7-003	C6	20	6	17227-ZM7-000	C11	25	4	87000				94050-05000	C8	22	11
14451-ZM7-000	C6	20	7	17228-ZM7-000	C11	25	5					94050-06000	C15	29	11
14711-ZM7-000	C6	20	8	17230-ZM7-000	C11	25	6	87521-Z7Y-000	C16	30	1	94050-10000	C14	28	6
14721-ZM7-000	C6	20	9	17231-ZM7-000	C11	25	7					94101-04200	C13	27	21
14731-ZM7-013	C6	20	10	17511-Z4D-000	C13	27	4	89000				94103-06800	C13	27	22
14732-Z0G-003	C6	20	11	17517-ZN4-000	C13	27	5					94251-04000	C13	27	23
14751-ZM7-000	C6	20	12	17532-ZM7-000	C13	27	6	89216-130-690	C16	30	2	94251-06000	C1	15	14
14754-ZM7-000	C6	20	13	17620-ZV0-020	C13	27	7					94301-06100	C3	17	13
14771-ZM3-010	C6	20	14	17621-ZV0-020	C13	27	8	90000							
				17622-ZV0-000	C13	27	9					95000			
				17623-ZV0-000	C13	27	10	90001-ZM7-000	C5	19	6				
15000				17624-ZV0-000	C13	27	11	90002-ZM7-000	C12	26	5	95002-02080	C13	27	24
15171-ZN4-000	C1	15	4	17625-ZV0-000	C13	27	12	90002-ZM7-000	C12	26	5	95002-02100	C13	27	25
15361-Z0G-000	C6	20	15	17626-ZV0-010	C13	27	13	90002-ZN4-A50	C3	17	7	95002-02130	C13	27	26
15571-ZM7-003	C1	15	5	17628-ZV0-000	C13	27	14	90003-892-000	C1	15	9				
15572-ZM7-000	C1	15	6	17629-ZV0-000	C13	27	15								
15600-ZN4-003	C2	16	2	17701-ZN4-800	C13	27	16								
15625-ZE1-003	C2	16	3					90004-ZC3-000	C14	28	5	96000			
15631-ZN4-000	C2	16	4	18000				90004-ZN4-000	C11	25	8				
15721-ZN4-000	C11	25	1					90006-ZM7-000	C2	16	5	96220-60150	C1	15	15
				18310-ZM7-003	C12	26	1								
16000				18310-ZM7-801	C12	26	1	90008-ZM7-000	C1	15	10	98000			
16010-ZG2-D10	C10	24	1	18320-ZM7-000	C12	26	2	90012-892-000	C12	26	6				
16011-ZE0-005	C10	24	2	18350-ZM7-801	C12	26	3	90012-896-750	C2	16	6	98056-54757	C1	15	16
16013-ZG0-811	C10	24	3	18515-ZM7-000	C12	26	4	90012-ZM3-003	C8	22	9	98056-54777	C1	15	16
16015-ZG0-811	C10	24	4					90015-ZE5-010	C15	29	9	98056-55757	C1	15	16
16016-ZH7-W01	C10	24	5	19000				90015-ZG0-801	C13	27	19	98056-55777	C1	15	16
16024-ZE1-811	C10	24	6	19052-MB4-880	C13	27	17	90016-ZE7-W00	C15	29	10				
16028-ZG0-811	C10	24	7	19610-ZM7-000ZD	C9	23	1	90042-ZM7-000	C9	23	3	99000			
16044-ZM7-003	C10	24	8	19619-ZM7-300	C9	23	2	90043-ZM7-000	C9	23	4				
								90103-P4V-010	C12	26	7	99101-ZG0-0480	C10	24	17

3

PART NAME INDEX

Part name	Address	Page	Ref.	Part name	Address	Page	Ref.	Part name	Address	Page	Ref.
SCREW, PAN, 3X5	C1	15	13								
SCREW, RECESSED, 5X28	C15	29	10								
SCREW, SETTING	C8	22	9								
SCREW, TAPPING, 4X8	C12	26	10								
SCREW, THROTTLE STOP	C10	24	10								
SEAL, AIR CLEANER	C11	25	4								
SEAL, VALVE STEM	C6	20	1								
SHAFT, GOVERNOR ARM	C1	15	7								
SHROUD	C1	15	8								
SLIDER, GOVERNOR	C3	17	6								
SLINGER, OIL	C6	20	15								
SPONGE, FUEL CAP BREATHER	C13	27	10								
SPRING, CONTROL ADJUSTING	C15	29	6								
SPRING, FRICTION	C8	22	2								
SPRING, FUEL CAP	C13	27	15								
SPRING, GOVERNOR	C15	29	3								
SPRING, RECOIL STARTER	C8	22	5								
SPRING, THROTTLE RETURN	C15	29	4								
SPRING, VALVE	C6	20	12								
STARTER ASSY., RECOIL	C8	22	1								
STRAINER, FUEL	C13	27	3								
[T]											
TANK, FUEL	C13	27	4								
TUBE B, FUEL	C13	27	1								
TUBE, BREATHER	C11	25	1								
TUBE, FUEL TANK	C13	27	16								
[V]											
VALVE COMP., BREATHER	C13	27	13								
VALVE SET, FLOAT	C10	24	2								
VALVE, EX.	C6	20	9								
VALVE, IN.	C6	20	8								
VALVE, OIL OUTLET	C1	15	5								
[W]											
WASHER, 4.2X13	C3	17	9								
WASHER, 5.2X9	C1	15	11								
WASHER, DRAIN PLUG, 12MM	C3	17	10								
WASHER, PLAIN, 4MM	C13	27	21								
WASHER, PLAIN, 6MM	C13	27	22								
WEIGHT, GOVERNOR	C3	17	3								
WRENCH, SPARK PLUG	C16	30	2								

1

FOREWORD INDEX

2

ENGINE GROUP

3

PART NUMBER INDEX

4

PART NAME INDEX

HONDA
The Power of Dreams

January 28, 2007



PARTS CATALOGUE NEWS

Honda Motor Co., Ltd. Service Division

PARTS CATALOGUE - CORRECTED

Printed in Japan

CODE NO.	13Z7Y701
PARTS CATALOGUE NEWS	GXV57U
NEWS NO.	001

Block No.	Ref. No.	Note	Part No.	Description	Reqd. QTY	Serial No.	Parts catalogue code
					GXV 57U		
E-8	1	E	13010-ZM7-000	*PARTS NO. DELETION			
		D	13010-ZW6-000	RING SET, PISTON (STD.)	1		

NOTE A:PART NO. CHANGE D:NEWLY PROVIDED E:PART NO. DELETION K:REQUIRED NO. CORRECTION L:APPLICATION SERIAL NO. CORRECTION
T:APPLICATION CORRECTION Z:REMARKS CHANGE